

ARCH BY MARKUS JOHANSSON & JOHAN LINDSTEN,
BLOCKCHAIN & CIRRATA BY MARKUS JOHANSSON,
BALANCE BY VICTOR CASTANERA, MONDO BY ANTONIO
FACCO, TRAPEZE BY JETTE SCHEIB, NOTIC, STAIR &
SUPERWAVE BY NOTCHI ARCHITECTS,
LIGHTBONE BY FÄRG & BLANCHE, INSIDE 2.0
BY MORTEN & JONAS

2025 / 2026

oblure

SWEDEN

oblure

The name Oblure is a union between the words “Object” and “Allure”. The concept lies at the core of the brand driving the design and creation of alluring objects. Oblure was founded in 2017 in Gothenburg, Sweden with the desire to bring new innovative products in the field of lighting.

With our skills and roots cemented in Scandinavian design tradition, we endorse the simplicity, the minimalistic, and the functional but it doesn't end there. In the spirit of creativity, we want to add even more. For us a lamp is so much more than just light, it's a piece of art.

We therefore collaborate with international designers to create a collection with a distinct character, celebrating innovation that not only surprises but also intrigues. Our vision is to curate the original, the bold and the beautiful.

BLOCKCHAIN SYSTEM

The Blockchain System consists of aluminum cubes, attached together in an apparent random manner. A single cube traveling through time and space – rendering a sequence of positions for the beholder. Yet there is order in chaos, a millimeter precision to create this perfect silhouette. Every second cube is equipped with a custom-made LED panel designed and directed to spread a uniform light on whatever is below.

The cubes form an abstract silhouette in angles seemingly floating in the air. The Blockchain system is available in various lengths, starting from 1200 mm up to 3000 mm in a continuous line. Designed, engineered and handcrafted in Sweden, locally in Greater Gothenburg Metropolitan, the Swedish west coast.



BLOCKCHAIN 11 / BLACK PENDANT



BLOCKCHAIN 29 / BLACK / PENDANT





BLOCKCHAIN 17 / WHITE / PENDANT



BLOCKCHAIN 11 / ALUMINUM / PENDANT



BLOCKCHAIN 29 / BLACK / PENDANT



Markus Johansson (Sweden) graduated in 2011 from HDK (School of Design and Crafts) in Gothenburg, Sweden. Markus work with both Swedish and international brands and has won numerous awards and is represented at The Museum of Art and Design, New York.

LIGHTBONE

The Lightbone, a creation by FÄRG & BLANCHE, made its debut at the Armour Mon Amour exhibition during Milan Design Week 2017. Initially showcased in fabric and soaring up to 3 meters in height, these lamps drew inspiration from an unforgettable journey through Japan and its bamboo forests.

”We are thrilled to unveil the latest evolution of the LightBone floor lamp in collaboration with Oblure, this time crafted in solid oak wood and proudly made in Sweden,” shares the design duo, Färg & Blanche. This new version not only marks a transition in material, embracing the richness of solid oak, but also signifies our unwavering dedication to quality craftsmanship and sustainability.

Building on the Lightbone family, we are proud to introduce the Lightbone pendant/ceiling collection, available in sizes small, medium, and large. Each size encapsulates the essence of the original floor lamp, featuring the same meticulous design and solid oak wood construction. Additionally, these pendant/ceiling lights are thoughtfully equipped with a spotlight for downlight, adding a versatile touch to their luminous charm.

The Lightbone lights represent a harmonious blend of cultural inspiration and contemporary design. Whether showcased individually or grouped together, these lights create an enchanting ambiance, transforming your space into a sanctuary of style and sophistication.



LIGHTBONE / FLOORLAMP



LIGHTBONE / NATURAL OAK / FLOORLAMP





LIGHTBONE / BLUE OAK / FLOORLAMP



LIGHTBONE / NATURAL OAK / FLOORLAMP



LIGHTBONE / OAK / LARGE & MEDIUM PENDANT



LIGHTBONE / BLACK OAK / SMALL PENDANT



LIGHTBONE / NATURAL OAK / LARGE CEILING LAMP





LIGHTBONE / BLACK OAK / LARGE PENDANT



LIGHTBONE / BLUE & OAK / SMALL PENDANT LAMP



LIGHTBONE / BLUE OAK / MEDIUM AND LARGE PENDANT



FÄRG & BLANCHE (Sweden) was founded in 2010 by the Swedish designer Fredrik Färg and designer Emma Marga Blanche, born in France. As a studio, they work across a wide variety of fields, collaborating with established furniture brands such as BD Barcelona Design, Gärsnäs, Rörstrand, Petite Friture and Design House Stockholm to name a few, as well as producing their own collections and limited art pieces for galleries.

SUPERWAVE

Superwave brings to mind the ever-changing sea and how it can be translated into a strict geometry. The wave-shaped diffuser is not only a visual delight, but also designed to create optimal light distribution with high glare comfort.

Simultaneously, the uplight facet graces the ceiling with a soft, ambient radiance. This upward illumination creates an air of spaciousness, transforming even the smallest spaces.

The wires that suspend the fixture are not only practical but also contribute to its visual allure. Whether it hangs over the dining table or in the office landscape, Superwave is a pendant that impresses with its strong visual appearance and functionality.

Superwave features two standard colors. Furthermore, for a truly personalized touch, the pendant can be customized in any color of your choosing, providing you to align it seamlessly with your unique aesthetic vision.



SUPERWAVE / CUSTOM COLOR / PENDANT



SUPERWAVE / WHITE / PENDANT



SUPERWAVE / CUSTOM COLOR / PENDANT SYSTEM



SUPERWAVE / WHITE / PENDANT

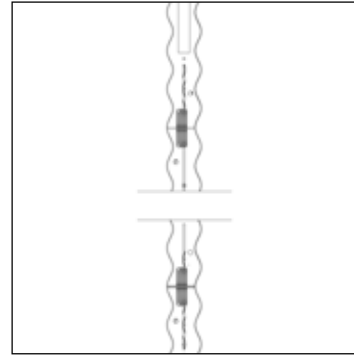
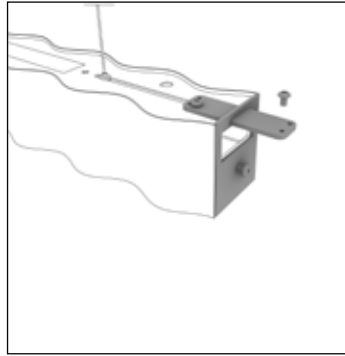

Fitting for straight line.

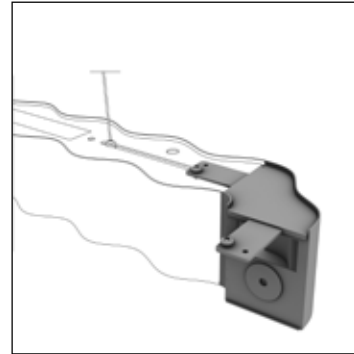
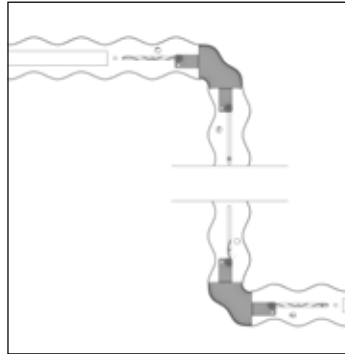

Fitting for 90 degrees corner, left or right.



Notchi Architects (Sweden)

integrates architecture and visual arts. Working with products, installations and architecture, the understanding of the relation between space and object is strong and the quest to find the right objects for a specific space sometimes results in new products.

STAIR LAMP

STAIR draws inspiration from the basic geometry of a solid stair block. The sphere sparks curiosity as it rests on the edge of time, capturing a “snapshot“ of movement in a series of events, creating a strong symbolic presence. When illuminated, the globe casts a beautiful shadow play.

The distinctive shape hides a set of functions as Stair is equipped with two USB-C ports on the side. In a digital world where people take technology for granted, this provides many user possibilities.



STAIR / RED / TABLE LAMP



STAIR / YELLOW AND RED / TABLE LAMP



STAIR / RED / TABLE LAMP



STAIR / RED / TABLE LAMP



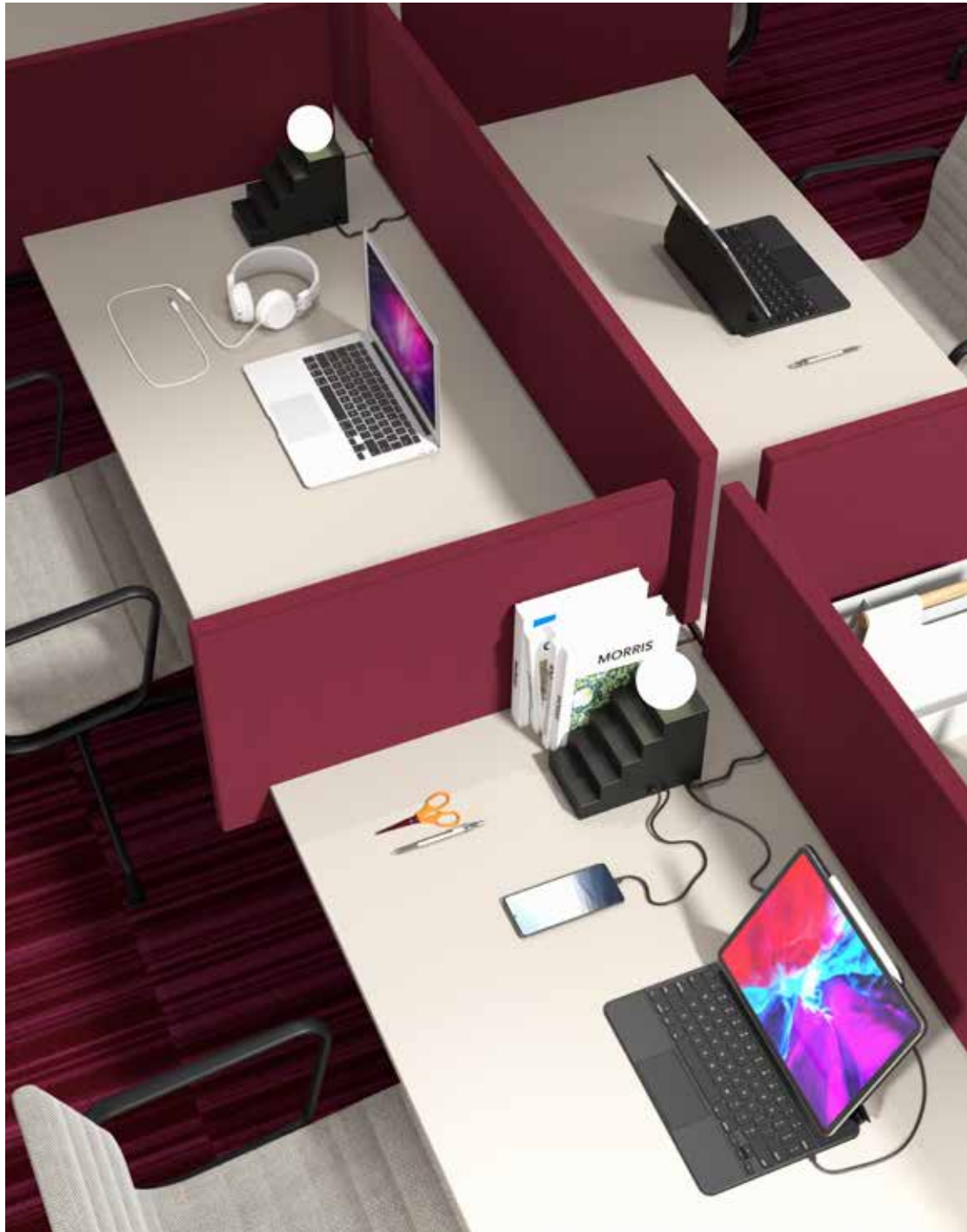

STAIR / BLACK / TABLE LAMP

Notchi Architects (Sweden) integrates architecture and visual arts. Working with products, installations and architecture the understanding of the relation between space and object is strong and the quest to find the right objects for a specific space sometimes results in new products.



BALANCE

All entities move and nothing remains still. Balance plays with the concept of time - everything is in motion. The impossible position of the orbs is an expression of the fragility of existence. The group of spheres stuck in time is a reminder to the beholder that life always moves, no matter what.

The construction is made from a pair of glowing orbs poised between two slanted steel boards. The metal spheres seen on both sides have just the right density to counterweight the opposite part of the lamps' weight. The overall structure is grounded on a robust foundation.



BALANCE / BLACK / TABLE LAMP





Victor Castanera (Spain) loves to experiment and the search for the different and emotional often result in the use of new techniques and materials. Living and working in Barcelona the Mediterranean culture is a big inspiration as well as his passion for the nature and the sea. The result is a collection of objects and products that speak for themselves in the simplest possible way.

ARCH

An arch shape travels from light to light, and in its entirety, forming a pendant that embodies and pays tribute to the architectural arches and vaults that have been built for centuries. Each pillar features a down light with precise glare control. The fixture has an alluring and eye-catching design with a metal exterior available in different colors. Arch Straight quickly became a favorite, and it wasn't long before several constellations were in demand.

Now, evolving into a circular form, the lamp reaches its design culmination with diameters of 760mm and 980mm, truly closing the circle. Arch continued to earn acclaim, leading to even more constellations. Welcoming the delightful additions, Arch Single and Arch Triplette, these siblings complement the family.

"We view these members as an extension, contributing to the Arch's evolution into a cohesive family."



ARCH STRAIGHT / BLUE / PENDANT



ARCH STRAIGHT / CUSTOM COLOR / PENDANT



ARCH STRAIGHT / BLACK / PENDANT



ARCH SINGLE & TRIPLETTE / WHITE / PENDANT



ARCH SINGLE / BLACK / PENDANT



ARCH CIRCLE 76/ CUSTOM COLOR / PENDANT



ARCH TRIPLETTE/ CUSTOM COLOR / PENDANT



ARCH CIRCLE 98 / NUDE / PENDANT



ARCH TRIPLETTE / NUDE / PENDANT



ARCH CIRCLE 76 / CUSTOM COLOR / PENDANT





ARCH STRAIGHT / WHITE / PENDANT



Johan Lindsten (Sweden) was born in 1981 in the heart of, Möbelriket', the furniture kingdom of Sweden. Profiting from a vast knowledge about the industry at an early age he successfully graduated in the program of furniture design in Stockholm in 2008, leading to the establishment of the independent Design Studio Johan Lindstén Form.

Markus Johansson (Sweden) graduated in 2011 from HDK (School of Design and Crafts) in Gothenburg, Sweden. Markus work with both Swedish and international brands and has won numerous awards and is represented at The Museum of Art and Design, New York.

MONDO

Mondo pendant has a classic soul but contemporary ambitions. It combines a planetary physical presence with an abstract concept of originality, shaped by the beholder. The ability to interact with the lamp creates an infinite dialogue between the user and the design.

The overlapping patterns control the luminous effect through the movement of the metallic shades. Antonio Facco has created a sophisticated lamp that invites the user to become a co-designer.



MONDO LARGE / BLACK / PENDANT



MONDO LARGE / BLACK / FLOOR LAMP





MONDO LARGE / CHROME CUSTOM COLOR / PENDANT



MONDO LARGE / CHROME & NUDE CUSTOM COLOR / PENDANT



MONDO SMALL / BLACK / FLOOR LAMP

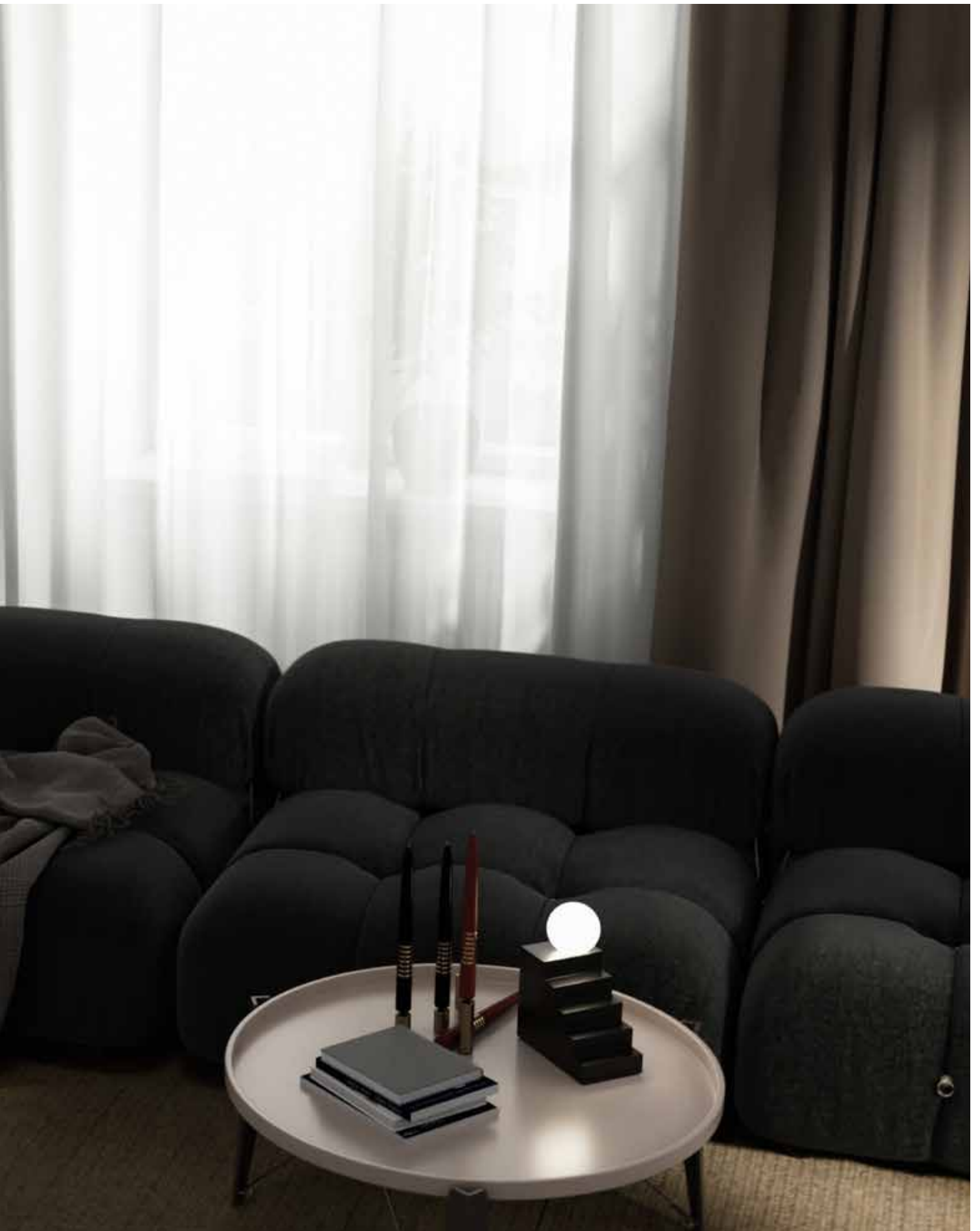



MONDO SMALL / BLACK / PENDANT



Antonio Facco (Italy) always paid great attention to the evolution of contemporary design and communication. Through the analysis of new generations' behavior and habits he draws hints and inspiration for his own research and projects. Antonio is strongly connected to Cassina furniture brand and with his own studio, he work across a wide variety of fields, collaborating with other well established furniture brands such as BOLON, Mogg to name a few.

TRAPEZE

Trapeze is a true artist, an aerialist combining grace and style. Fixed in a single pose with endless possibilities. Each shade can be directed 360 degrees, allowing the user the choice to combine uplight and downlight simultaneously. A playful and bold feature that's both visually striking and highly functional..

Trapeze is available in three versions. The single pendant with two shades, the 'Triplette' with six shades and the 'Quartet' with eight shades. Each fixture allows for diffused light direction, ensuring illumination exactly where it is needed.



TRAPEZE / BLACK / PENDANT



TRAPEZE TRIPLETTE / BLACK / PENDANT





Jette Scheib (Germany)
studied Industrial Design at the University of the Arts in Berlin. "I am inspired by nature and organic shapes, but also by people and everyday life. I am observing my surroundings, I study objects, people, people interacting with objects and each other."



TRAPEZE QUARTETTE / BLACK / PENDANT

CIRRATA

Unexpected experiences and surprises await deep down on the ocean floor: a body with many arms illuminates the depths. Arrogant and presumptuous, there's no doubt who rules down here. A lonely yet unafraid character with forms born out of the resemblance to other mysterious ocean inhabitants.

The character is Cirrata, a glowing lamp in the darkness of the ocean. Markus Johansson has created a lamp that challenges all ideas about what aluminum can become. The symmetrical arms evenly carry the weight of the lamp.



CIRRATA / WHITE / TABLE LAMP



CIRRATA / GREY / TABLE LAMP



Markus Johansson (Sweden) graduated in 2011 from HDK (School of Design and Crafts) in Gothenburg, Sweden. Markus work with both Swedish and international brands and has won numerous awards and is represented at The Museum of Art and Design, New York.

NOTIC

Notic is an homage to classical architectural elements. The metal shade embraces the glass's complex geometry, casting light in a hypnotic way. The lamp features focused downlight combined with gentle illumination through the shade. Resembling a hypnotic pendulum, it invites the beholder to reflect.

The idea behind the lamp was to design a focus point in a three-dimensional space. Notic offers virtual lines and directions to guide the visitor and define spatiality. The sharp contrast draws immediate attention.



NOTIC / BLACK / WALL LAMP



NOTIC / BLACK / PENDANT



NOTIC / BLACK / TABLE LAMP



NOTIC / BLACK / TABLE LAMP



Notchi Architects (Sweden) integrates architecture and visual arts. Working with products, installations and architecture the understanding of the relation between space and object is strong and the quest to find the right objects for a specific space sometimes results in new products.

INSIDE 2.0

Inside pendant is a tribute to the most generous and kind lady in the city of Bergen, Norway. The pendant is an attempt to materialize her genuine enthusiasm, passion and knowledge about design into a single object.

The name comes from the twisted glass. The swirl shape makes every lamp unique, diffusing and spreading the light in a gentle wave pattern. The pattern is an extension of the design and what makes Inside so special.



INSIDE 2.0 / PENDANT



INSIDE 2.0 / PENDANT



Notchi Architects (Sweden) integrates architecture and visual arts. Working with products, installations and architecture the understanding of the relation between space and object is strong and the quest to find the right objects for a specific space sometimes results in new products.

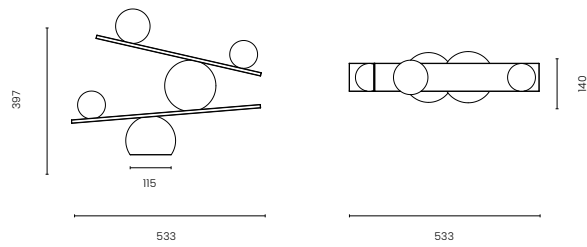

**TECHNICAL
SPECIFICATIONS**



Balance Table Lamp (2016) P. 18

Victor Castanera (Spain)

Description: Table lamp in steel with two opal glass. Glossy black paint (Black) and PVD coated brass and chrome. With interchangeable multi wall plug adapter for multi-country use.

Colors:	Black	VCBAI003	
	Brass	VCBAI010	
	Chrome	VCBAI011	



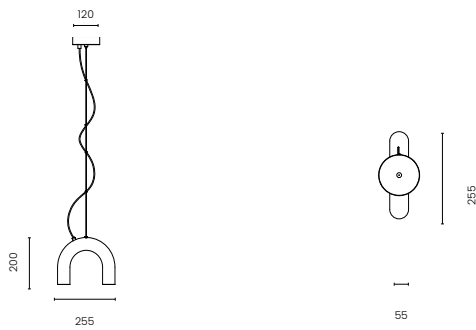

Environment: Indoor
 Watt: 5,5W (3,5W + 2W)
 Measurements: 397 mm (H), 533 mm (L), 140 mm (W)
 Cord: 180 cm
 LED info*: Custom LED (included and replaceable)
 CCT 2700K, dimmable, CRI 90, 50.000h



Arch Single Pendant (2024) P. 49

Johan Lindsten (Sweden), Markus Johansson (Sweden)

Description: Pendant lamp in steel, bent and welded by hand. Each pillar is equipped with GU10 sockets. The lamp suspension details are in chrome finish, as well as the ceiling canopy. Suspension wires are adjustable with a griplock* and power cable in transparent cover.

Colors:	White	MJAR2001.S	
	Black	MJAR2003.S	
	Blue	MJAR2006.S	
	Nude	MJAR2008.S	
	Custom	MJAR20.SXX	

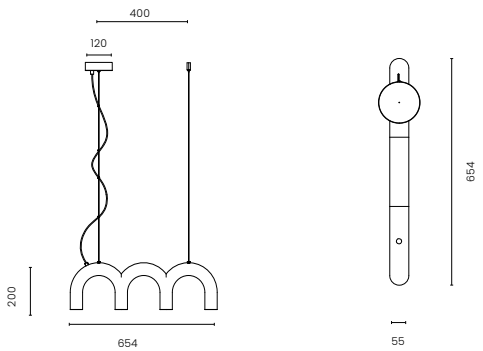

Environment: Indoor
 Watt: max 2 x 20W (LED)
 Measurements: 200 mm (H), 255 mm (L), 55mm (W)
 Cord: 300 cm
 Fitting: GU10 (PAR16 Light bulb not included)



Arch Triplette Pendant (2024) P. 48

Johan Lindsten (Sweden), Markus Johansson (Sweden)

Description: Pendant lamp in steel, bent and welded by hand. Each four pillars are equipped with a GU10 socket. Suspension fittings are in chrome finish, as well as the ceiling canopy. Suspension wires are adjustable with an griplock* and power cable in transparent cover.

Colors:	White	MJAR2001.T	
	Black	MJAR2003.T	
	Blue	MJAR2006.T	
	Nude	MJAR2008.T	
	Custom	MJAR20.TXX	



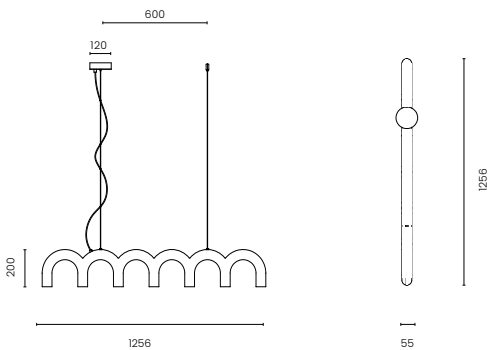

Environment: Indoor
 Watt: max 4 x 20W (LED)
 Measurements: 200 mm (H), 654 mm (L), 55 mm (W)
 Cord: 300 cm
 Fitting: GU10 (PAR16 Light bulb not included)



Arch Straight Pendant (2021) P. 45

Johan Lindsten (Sweden), Markus Johansson (Sweden)

Description: Pendant lamp in steel, bent and welded by hand. Each seven pillars equipped with GU10 sockets. The lamp suspension details are in chrome finish, as well as the ceiling canopy. Suspension wires are adjustable with a griplock* and power cable in transparent cover.

Colors:	White	MJAR2001	
	Black	MJAR2003	
	Blue	MJAR2006	
	Nude	MJAR2008	
	Custom	MJAR20.XX	

Environment: Indoor
 Watt: max 7 x 20W (LED)
 Measurements: 200 mm (H), 1256 mm (L), 55mm (W)
 Cord: 300 cm
 Fitting: GU10 (PAR16 Light bulb not included)



LED info*: Updated and detailed information, please see product sheet or website.

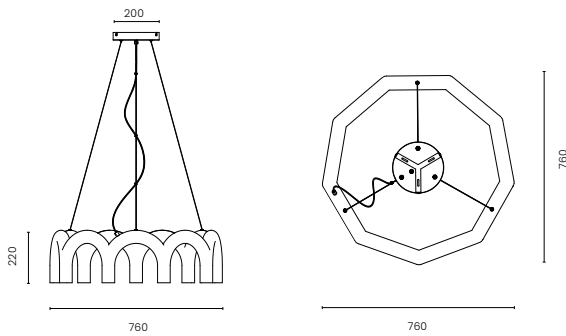

Arch Circle 760 (2023) P. 50

Johan Lindsten (Sweden), Markus Johansson (Sweden)

Description: Circle pendant lamp in steel, bent and welded by hand. Each nine pillars are equipped with a GU10 socket. Suspension fittings are in chrome finish, as well as the ceiling canopy. Suspension wires are adjustable with a griplock® and power cable in transparent cover.

- Colors: White MJAR2001.C1
 Black MJAR2003.C1
 Blue MJAR2006.C1
 Nude MJAR2008.C1
 Custom MJAR20.C1.XX

Environment: Indoor
 Watt: max 9 x20 W (LED)
 Measurements: 220 mm (H), 760 mm (∅)
 Cord: 300 cm
 Fitting: GU10 (PAR16 Light bulb not included)

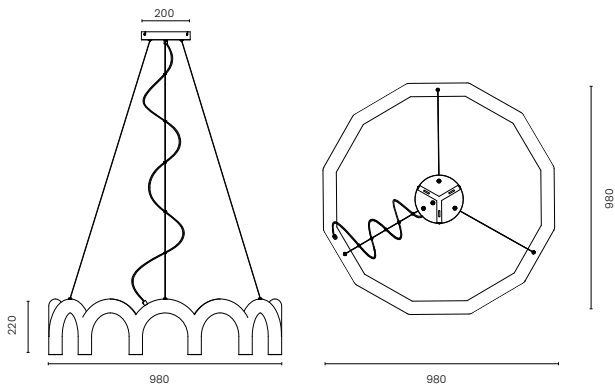

Arch Circle 980 (2024) P. 52

Johan Lindsten (Sweden), Markus Johansson (Sweden)

Description: Pendant lamp in steel, bent and welded by hand. Each eleven pillars are equipped with a GU10 socket. Suspension fittings are in chrome finish, as well as the ceiling canopy. Suspension wires are adjustable with a griplock® and power cable in transparent cover.

- Colors: White MJAR2001.C2
 Black MJAR2003.C2
 Blue MJAR2006.C2
 Nude MJAR2008.C2
 Custom MJAR20.C2.XX

Environment: Indoor
 Watt: max 12 x 20W (LED)
 Measurements: 220 mm (H), 980 mm (∅)
 Cord: 300 cm
 Fitting: GU10 (PAR16 Light bulb not included)

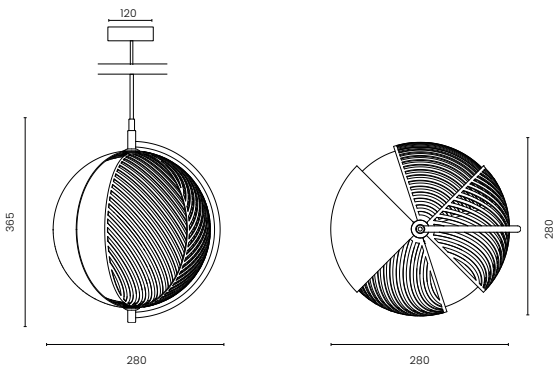

Mondo Pendant (2018) P. 67

Antonio Facco (Italy)

Description: Steel and opal glass. Pendant lamp with four metal shades, mounted in pairs. Allows the beholder to interact with the lamp.

- Colors: Black AFMO2003

Environment: Indoor
 Watt: Max 40w
 Measurements: 365 mm (H), 280 mm (∅)
 Cord: 300cm
 Fitting: E27 (Light bulb not included)

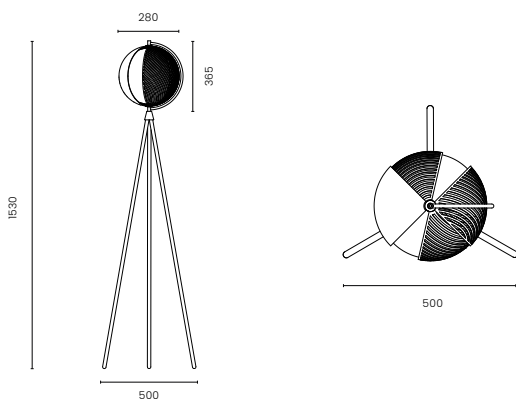

Mondo Floor (2018) P. 62

Antonio Facco (Italy)

Description: Floor lamp with four metal shades, mounted in pairs. Allows the beholder to interact with the lamp. Cable with on-off switch.

- Colors: Black AFMO3003

Environment: Indoor
 Watt: Max 40w
 Measurements: 365 mm (H), 280 mm (∅)
 (Shade/glass) 1530 mm (H), 500 mm (∅)
 (Height/base)
 Cord: 180cm
 Fitting: E27 (Light bulb not included)
 Cable dimmer switch.

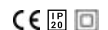

LED info*: Updated and detailed information, please see product sheet or website.

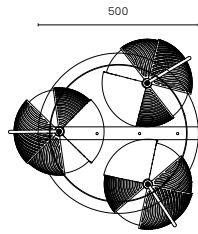
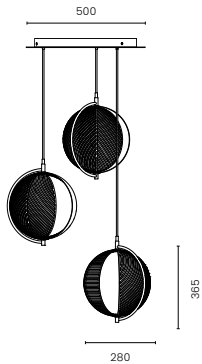

Mondo Triplette (2018) P. 66

Antonio Facco (Italy)

Description: Configuration of three Mondo pendants. The movable shades allow the beholder to interact with the lamp. Finished with matt Black paint.

Environment: Indoor
 Watt: Max 3 x 40 W
 Cord: 300cm
 Measurements: Each lamp: 365 mm (H), 280 mm (Ø)
 Canopy: 500 mm (Ø), 38 mm (H)
 Fitting: E27 (Light bulb not included)

Colors: Black AFMO2003.X3 ●

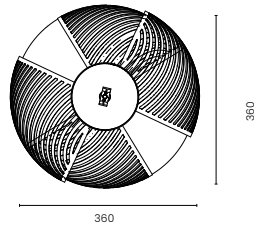
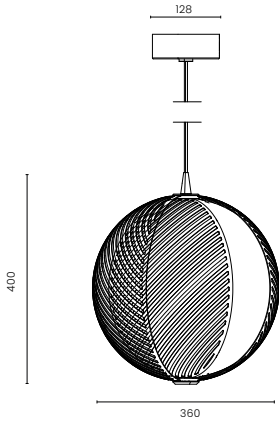
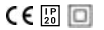

Mondo Large Pendant (2018) P. 59

Antonio Facco (Italy)

Description: Steel and opal glass. Pendant lamp with four metal shades, mounted in pairs. Allows the beholder to interact with the lamp.

Environment: Indoor
 Watt: 10W
 Measurements: 400 mm (H), 360mm (Ø)
 Cord: 300cm
 LED info*: 10W, output 750lm, CCT 3000K, CRI 90, SDCM 3, L80>50.000h, Driver: Phase cut dimmable, 110/230V.

Colors: Black AFMO2003.V2 ●
 Custom AFMO20XX.V2 ●●●

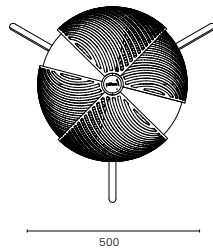
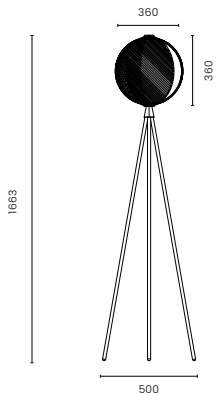
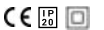

Mondo Large Floor (2018) P. 60

Antonio Facco (Italy)

Description: Floor lamp with four metal shades, mounted in pairs. Allows the beholder to interact with the lamp. Cable with dimmer switch.

Environment: Indoor
 Watt: 9W
 Measurements: 360 mm (H), 360 mm (Ø)
 Leg height 1530 mm (H), 500 mm (Ø)
 Cord: 180cm
 10W, output 750lm, CCT 3000K, CRI 90, SDCM 3, L80>50.000h, Wall plug adaptor with cable dimmer switch

Colors: Black AFMO3003.V2 ●
 Custom AFMO20XX.V2 ●●●

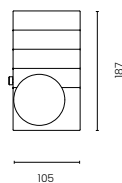
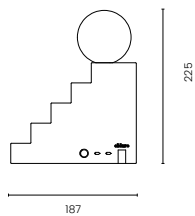
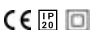

Stair Table (2022) P. 33

Notchi Architects (Sweden)

Description: Table lamp in steel and opal glass sphere equipped with G9 socket and rotary dimmer switch. The lamp also features with 2 x USB C charging ports.

Environment: Indoor
 Watt: Max 3 W (LED)
 Measurements: 225 mm (H), 187 mm (L), 105 mm (W)
 Cord: 300 cm
 Fitting: G9 (Light bulb not included, use a dimmable light bulb.)
 Futures: 2 x output USB-C charging port
 Charging all Android phones, iPhone up to 14.

Colors: Black NAST1003 ●
 Yellow NAST1005 ●●
 Red NAST1007 ●●●

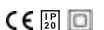

LED info*: Updated and detailed information, please see product sheet or website.

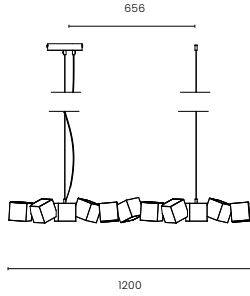

Blockchain 11 (2019) P. 5

Markus Johansson (Sweden)

Description: Pendant lamp providing downlight from every second cubes. Dimmable LED driver (DALI/PUSH DIM) is provided and fitted in the canopy. Steel wire suspensions and transparent cable.

Environment: Indoor
 Watt: 6 x 5W
 Measurements: 1200 mm (L), 100 mm (W), 100 mm (H)
 Cord: 300 cm
 LED info:* LED (replacable-spare part)
 lm output 2400 lm , CCT 3000K, SDCM 3, CRI 90, L90>100.000h, Driver: Pushdim, DALI

Colors: White MJBL2001.X11
 Black MJBL2003.X11
 Alu. MJBL2012.X11

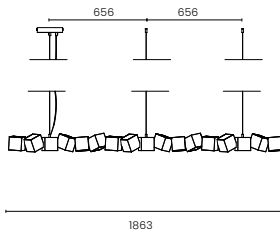

Blockchain 17 (2019) P.8

Markus Johansson, Sweden

Description: Pendant lamp providing downlight from every second cubes. Dimmable LED driver (DALI/PUSH DIM) is provided and fitted in the canopy. Steel wire suspensions and transparent cable.

Environment: Indoor
 Watt: 9 x 5W
 Measurements: 1863 mm (L), 100 mm (W), 100 mm (H)
 Cord: 300 cm
 LED info:* LED (replacable-spare part)
 lm output 4050 lm , CCT 3000K, SDCM 3, CRI 90, L90>100.000h, Driver: Pushdim, DALI

Colors: White MJBL2001.X17
 Black MJBL2003.X17
 Alu. MJBL2012.X17

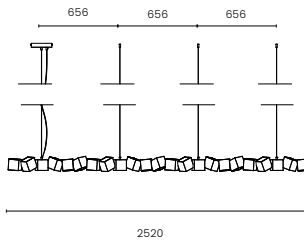

Blockchain 23 (2019) P. 6

Markus Johansson (Sweden)

Description: Pendant lamp providing downlight from every second cubes. Dimmable LED driver (DALI/PUSH DIM) is provided and fitted in the canopy. Steel wire suspensions and transparent cable.

Environment: Indoor
 Watt: 12 x 5W
 Measurements: 2520 mm (L), 100 mm (W), 100 mm (H)
 Cord: 300 cm
 LED info:* LED (replacable-spare part)
 lm output 5400 lm , CCT 3000K, SDCM 3, CRI 90, L90>100.000h, Driver: Pushdim, DALI

Colors: White MJBL2001.X23
 Black MJBL2003.X23
 Alu. MJBL2012.X23

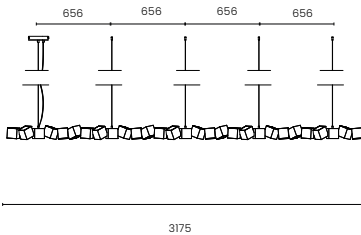

Blockchain 29 (2019) P. 10

Markus Johansson, Sweden

Description: Pendant lamp providing downlight from every second cubes. Dimmable LED driver (DALI/PUSH DIM) is provided and fitted in the canopy. Steel wire suspensions and transparent cable.

Environment: Indoor
 Watt: 15 x 5W
 Measurements: 281 (H), 374 mm (Ø)
 Cord: 300cm
 LED info:* LED (replacable-spare part)
 lm output 6750 lm , CCT 3000K, SDCM 3, CRI 90, L90>100.000h, Driver: Pushdim, DALI.

Colors: White MJBL2001.X29
 Black MJBL2003.X29
 Alu. MJBL2012.X29



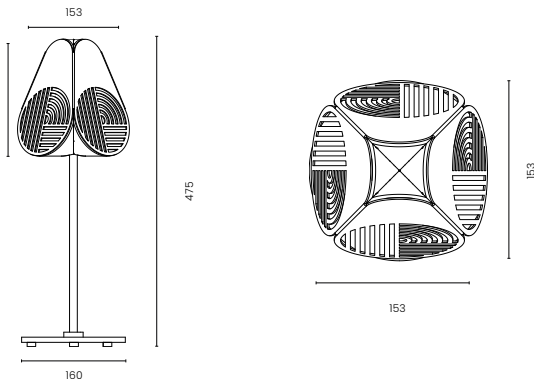

Notic Table Lamp (2019) P. 81

Notchi (Sweden)

Description: Table lamp in patterned steel and casted opal glass. Complex geometry, textile cord.

Environment: Indoor
 Watt: Max 25 W
 Measurements: 475 mm (H), 153 mm (W), 153 mm (D)
 Cord: 2100 mm
 Fitting: G9 (Light bulb not included)

Colors: Black BSNO1003

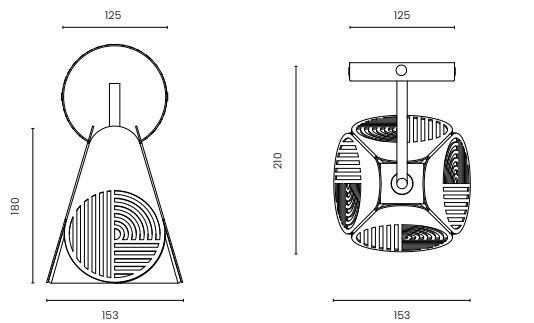

Notic Wall (2019) P. 79

Notchi (Sweden)

Description: Wall lamp in patterned steel and casted opal glass. Complex geometry, textile cord.

Environment: Indoor
 Watt: Max 25 W
 Measurements: 180 mm (H), 153 mm (W), 153 mm (D), 210 mm (From wall to edge of the shade)
 Fitting: G9 (Light bulb not included)

Colors: Black BSNO4003

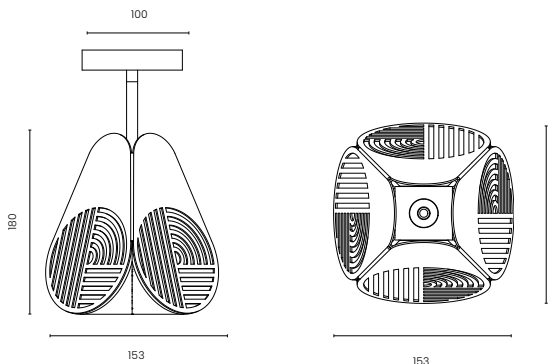
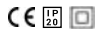

Notic Ceiling (2019) P. 80

Notchi (Sweden)

Description: Ceiling lamp in patterned steel and casted opal glass. Complex geometry, textile cord.

Environment: Indoor
 Watt: Max 25 W
 Measurements: 180 mm (H), 153 mm (W), 153 mm (D)
 Cord: 300 cm
 Fitting: G9 (Light bulb not included)

Colors: Black BSNO2003

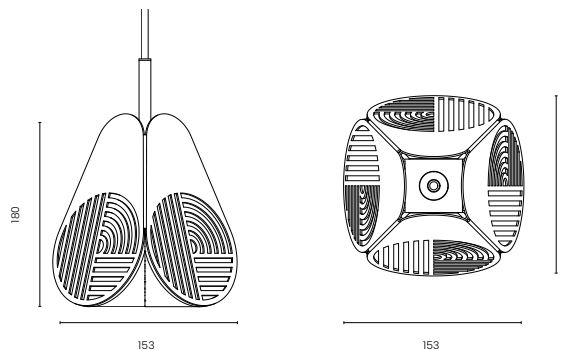
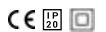

Notic Pendant (2019) P. 80

Notchi (Sweden)

Description: Pendant lamp in patterned steel and casted opal glass. Complex geometry, textile cord.

Environment: Indoor
 Watt: Max 25 W
 Measurements: 180 mm (H), 153 mm (W), 153 mm (D)
 Cord: 300 cm
 Fitting: G9 (Light bulb not included)

Colors: Black BSNO2003



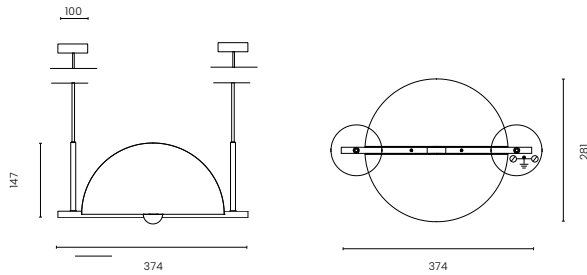

Trapeze Pendant (2018) P. 69

Jette Scheib (Germany)

Description: Steel with acrylic diffuser. Pendant lamp providing light in two different directions. Rotate each shade individual. Ceiling cup with fabric cable (1 electric terminal block).

Colors: Black JSTR2003



Environment: Indoor
 Watt: Max 2 x 20 W
 Measurements: 374mm (H), 281 mm (W), 147 mm (H)
 Cord: 300cm
 Fitting: 2 x E14 (Light bulb not included)

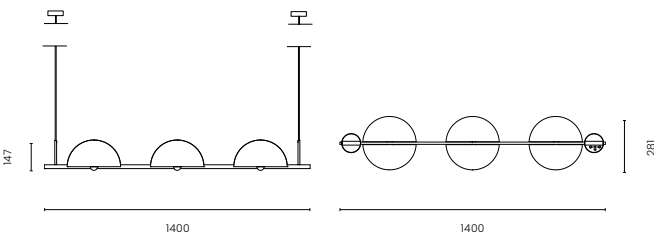

Trapeze Triplette (2018) P. 70

Jette Scheib (Germany)

Description: Steel with acrylic diffuser. Pendant lamp providing light in six directions. Rotate each shade individual. Ceiling cups with fabric cable (1 electric terminal block).

Colors: Black JSTR2003.X3



Environment: Indoor
 Watt: Max 6 x 20 w
 Measurements: 1400 mm (L) x 281 mm (W) x 147 mm (H)
 Cord: 300cm
 Fitting: 6 x E14 (Light bulb not included)

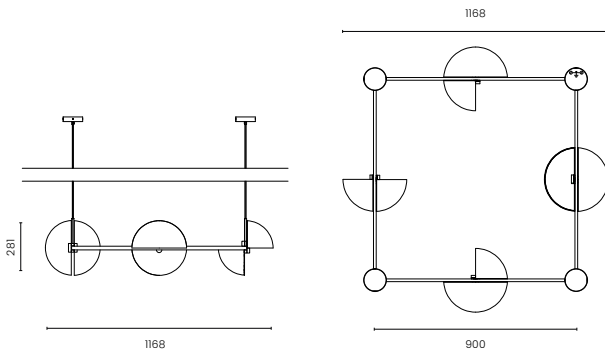

Trapeze Quartette (2018) P. 73

Jette Scheib (Germany)

Description: Steel with acrylic diffuser. Pendant lamp providing light in eight directions. Rotate each shade individual. Ceiling cups with fabric cable (1 electric terminal block).

Colors: Black JSTR2003.X4



Environment: Indoor
 Watt: Max 8 x 20 w
 Measurements: 900 mm tube, 1168mm total length x 281 mm (H)
 Cord: 300cm
 Fitting: 8 x E14 (Light bulb not included)

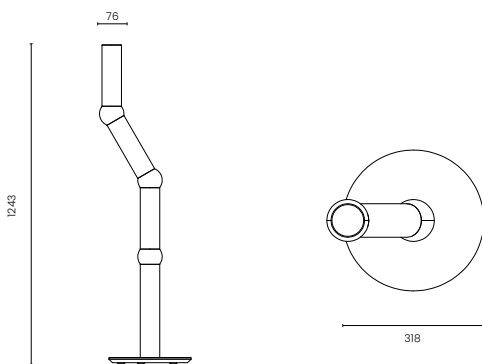
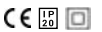

Lightbone Floor lamp (2023) P. 13

FÄRG & BLANCHE (Sweden/France)

Description: Floor lamp in solid oak wood, opal glass as connections, recessed solid brass plate on top as a rotating dimmer switch. The color version are made with linseedoil.

Colors: Blue oak FBLL3006



Black oak FBLL3003



Natural oak FBLL3013



Environment: Indoor
 Watt: Max 3 x 3 w
 Measurements: 1243 mm (H) x 318 mm (Ø Base), 76 mm (Ø Pipe)
 Cord: 180cm
 LED info*: LED 3 x 3W, 750 lm, CCT 2700K, SDGM 3, CRI 90, L90>50.000h, rotary dimmer switch.



LED info*: Updated and detailed information, please see product sheet or website.

Lightbone Small Ceiling lamp (2023) P. 21

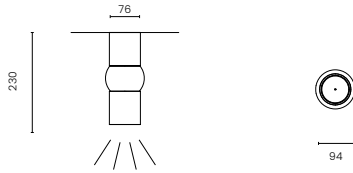

FÄRG & BLANCHE (Sweden/France)

Description: Ceiling lamp in solid oak wood, opal glass as a connection for ambient light, downlight with reflector for direct light. The color versions are made with linseedoil.

Colors: Black oak FBI2003.S
Blue oak FBI2006.S
Natural oak FBI2013.S

Environment: Indoor
Measurements: 230 mm (H) x 94 mm (Ø)
Cord: 300cm
LED info*: 10W Downlight 1000 lm, 3W opal glass 250 lm, CCT 2700K, CRI 90, SDCM 3, L80>50.000h.
Beam angle: 36°
Driver: Phase cut dimmable

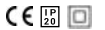

Lightbone Small Pendant lamp (2023) P. 19

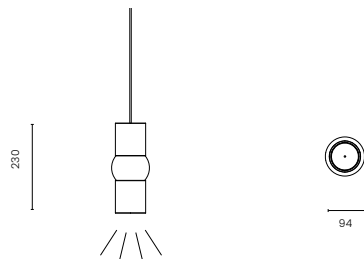

FÄRG & BLANCHE (Sweden/France)

Description: Pendant lamp in solid oak wood, opal glass as a connection for ambient light, downlight with reflector for direct light. The color versions are made with linseedoil.

Colors: Black oak FBI2003.S
Blue oak FBI2006.S
Natural oak FBI2013.S

Environment: Indoor
Measurements: 230 mm (H) x 94 mm (Ø),
Cord: 300cm
LED info*: 10W Downlight 1000 lm, 3W opal glass 250 lm, CCT 2700K, CRI 90, SDCM 3, L80>50.000h.
Beam angle: 36°
Driver: Phase cut dimmable



Lightbone Medium Ceiling lamp (2023) P. 18

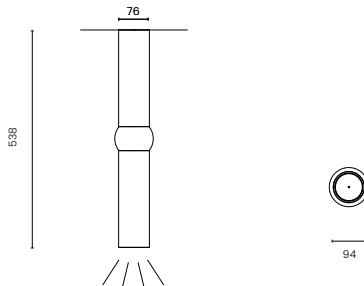

FÄRG & BLANCHE (Sweden/France)

Description: Ceiling lamp in solid oak wood, opal glass as a connection for ambient light, downlight with reflector for direct light. The color versions are made with linseedoil.

Colors: Black oak FBI2003.M
Blue oak FBI2006.M
Natural oak FBI2013.M

Environment: Indoor
Measurements: 538 mm (H) x 94 mm (Ø),
Cord: 300cm
LED info*: 10W Downlight 1000 lm, 3W opal glass 250 lm, CCT 2700K, CRI 90, SDCM 3, L80>50.000h.
Beam angle: 36°
Driver: Phase cut dimmable



Lightbone Medium Pendant lamp (2023) P. 18

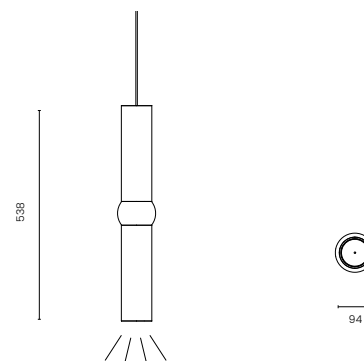

FÄRG & BLANCHE (Sweden/France)

Description: Pendant lamp in solid oak wood, opal glass as a connection for ambient light, downlight with reflector for direct light. The color versions are made with linseedoil.

Colors: Black oak FBI2003.M
Blue oak FBI2006.M
Natural oak FBI2013.M

Environment: Indoor
Measurements: 538 mm (H) x 94 mm (Ø),
Cord: 300cm
LED info*: 10W Downlight 1000 lm, 3W opal glass 250 lm, CCT 2700K, CRI 90, SDCM 3, L80>50.000h.
Beam angle: 36°
Driver: Phase cut dimmable



LED info*: Updated and detailed information, please see product sheet or website.

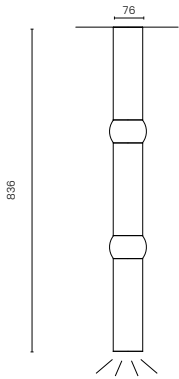

Lightbone Large Ceiling lamp (2023) P. 20

FÄRG & BLANCHE (Sweden/France)

Description: Ceiling lamp in solid oak wook, opal glass as a connection for ambient light, downlight with reflector for direct light. The color versions are made with linseedoil.

Colors: Black oak FBI2003.L

Blue oak FBI2006.L

Natural oak FBI2013.L



Environment: Indoor

Measurements: 836 mm (H) x 94 mm (Ø),

Cord: 300cm

LED info*: 10W Downlight 1000 lm, 2 x 3W opal glass 250 lm, CCT 2700K, CRI 90, SDCM 3, L80>50.000h.

Beam angle: 36°

Driver: Phase cut dimmable

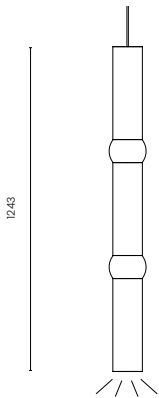
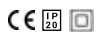

Lightbone Large Pendant lamp (2023) P. 18

FÄRG & BLANCHE (Sweden/France)

Description: Pendant lamp in solid oak wook, opal glass as a connection for ambient light, downlight with reflector for direct light. The color versions are made with linseedoil.

Colors: Black oak FBI2003.L

Blue oak FBI2006.L

Natural oak FBI2013.L



Environment: Indoor

Measurements: 836 mm (H) x 94 mm (Ø),

Cord: 300cm

LED info*: 10W Downlight 1000 lm, 2 x 3W opal glass 250 lm, CCT 2700K, CRI 90, SDCM 3, L80>50.000h.

Beam angle: 36°

Driver: Phase cut dimmable

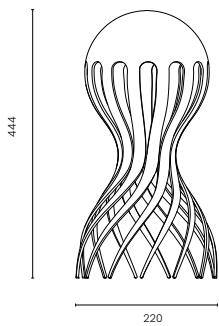
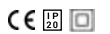

Cirrata Table (2011) P. 75

Markus Johansson (Sweden)

Description: Table lamp is made in aluminum with a decorative light effect. Textile cable with dimmer switch. Interchangeable multi wall plug adapter for multi country use.

Colors: White MJCI1001

Grey MJCI1002



Environment: Indoor

Watt: 3.2 W

Measurements: 444 mm (H), 220 mm (Ø)

Cord: 180cm

Fitting: LED (replaceable) 2700K

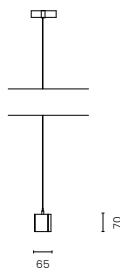
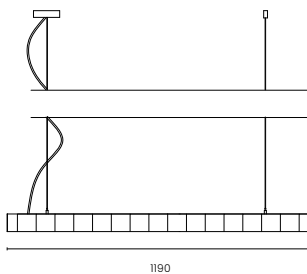
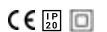

Superwave Pendant (2024) P. 27

Notchi Architects (Sweden)

Description: Pendant lamp in wave shape body and anti glare louvres. Downlight and uplight with suspension steel wire griplock® and transparent cable. Integrated driver.

Colors: White NASW2001

Custom NASW20.XX



Environment: Indoor

Watt: 46 W

Measurements: 1190 mm (L), 70 mm (H), 65 mm (W)

Cord: 300cm

LED info*: 102lm/W, 3289lm uplight, 1m, 1410lm downlight, CCT 3000K, CRI 90, SDCM 3, L90>100.000h.

DALI / Pushdim.

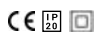

LED info*: Updated and detailed information, please see product sheet or website.

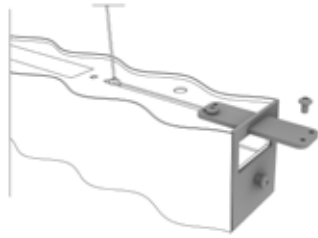

Superwave mid-connection (2025) P. 31

Notchi Architects (Sweden)

Description: Fitting for mid-section connection. Continuous fitting for straight line.

Colors: White NASW2001.MD



Custom NASW20.MD.XX



Environment: Indoor
Fitting: Mid section connection

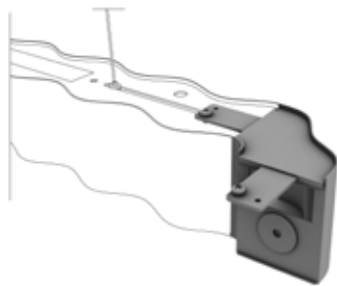
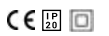

Superwave 90° corner (2025) P. 31

Notchi Architects (Sweden)

Description: Fitting for cornering 90degrees left or right turns.

Colors: White NASW2001.C90



Custom NASW20.C90.XX



Environment: Indoor
Fitting: 90 degree angle left and right

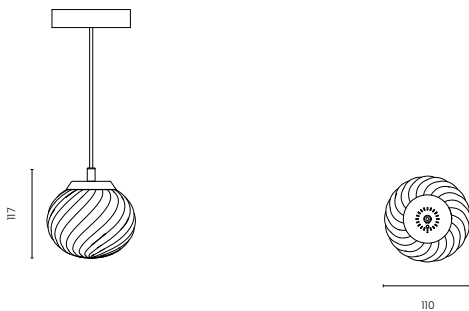

Inside 2.0 Single (2017) P. 85

Morten & Jonas (Norway)

Description: The pendant consist with a twisted glass. Metal parts in black. The light diffuses and spread a gentle wave pattern.

Colors: Black MJIN2000



Environment: Indoor
Watt: Max 5W
Measurements: 117 mm (H) 110 mm (Ø)
Cord: 300cm
LED info*: 10W, output 1004lm, CCT 3000K, CRI 90, SDCM 3, L80>50.000h, Driver: Phase cut dimmable

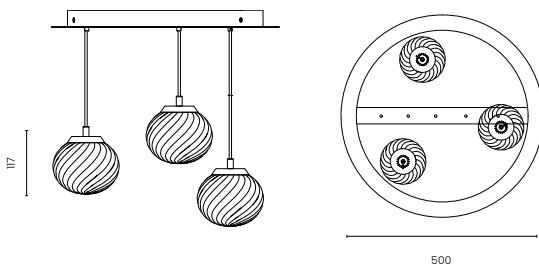

Inside 2.0 Triplette (2017) P. 86

Morten & Jonas (Norway)

Description: The pendant consist with a twisted glass. The light diffuses and spread a gentle wave pattern. Ceiling canopy pre set positions for tripple hanging.

Colors: Black MJIN2000.X3



Environment: Indoor
Watt: Max 3 x 5 W
Measurements: 117 mm (H) x 110 mm (Ø)
Cord: 300 cm
LED info*: 3x10 W, lm output 1004lm, CCT 3000K, CRI 90, SDCM 3, L80>50.000h, Driver: Phase cut dimmable



LED info*: Updated and detailed information, please see product sheet or website.

WHERE TO FIND US

WWW.OBLURE.COM

HEADQUARTERS

OFFICE
FABRIKSGATAN 38
41251 GOTHENBURG
TEL. +46(0)31-797 98 96

SHOWROOM

STAMPGATAN 8 EXTENDED COWORING
STAMPGATAN 8
41103 GOTHENBURG
TEL. +46(0)72-209 02 40

AGENTS

FINLAND + BALTICUM / NONEKA OY, PETRI PUOTINIEMI
INFO@NONEKA.FI , +358 40 060 4208

FRANCE / ROZENO, CORENTIN CADORET
C.CADORET@ROZENO.FR , +337 61 54 03 62

SPAIN / MADELEINE BLAIR
MADELEINE@OBLURE.COM, +34 616 721 258

POLAND, CZECHIA, SLOVAKIA , HUNGARY / PORTFOLIO, ANDZREJ ZYCH
ANDRZEJ@PORTFOLIO.PL , +48 604 063 464

ART DIRECTOR

MARKUS JOHANSSON DESIGN

EDITION

©2025 ALL RIGHTS RESERVED

oblure

OBLURE AB | FABRIKSGATAN 38 | 412 51 GOTHENBURG | SWEDEN
WWW.OBLURE.COM | INFO@OBLURE.COM
+46(0)31-797 98 96