

**ARCH** BY MARKUS JOHANSSON & JOHAN LINDSTEN  
**BLOCKCHAIN & CIRRATA** BY MARKUS JOHANSSON,  
**BALANCE** BY VICTOR CASTANERA, **MONDO** BY ANTONIO  
**FACCO, TRAPEZE** BY JETTE SCHEIB, **NOTIC & STAIR** BY  
**NOTCHI ARCHITECTS, HELIOS** BY JOAKIM THEDIN  
**LIGHTBONE** BY FÄRG & BLANCHE

2023 / 2024

**oblure**  
SWEDEN

## **oblure**

The name Oblure is a union between the words “Object” and “Allure”. The concept lays in the core of the brand in order to design and create alluring objects. Oblure was founded in 2017 in Gothenburg, Sweden with the desire to bring new innovative products in the field of lighting.

With our skills and roots that are cemented in the Scandinavian design tradition we endorse the simplicity, the minimalistic, and the functional but it does not end there. In the spirit of creativity, we want to add furthermore. For us a lamp is so much more than just light, it's a piece of art.

We therefore collaborate with international designers with our focus on creating a collection of products that shine a distinguishable character and celebrates innovative elements that not just surprise but also intrigue the beholder. Our vision is to curate the original, the bold and the beautiful.

## BLOCKCHAIN SYSTEM

The Blockchain System consists of extruded aluminum cubes, attached together apparently random. A single cube traveling through time and space – rendering a sequence of positions for the beholder. But there is order in chaos, a millimeter precision to create this perfect silhouette. Every second cube is lit with a custom-made LED panel designed and directed to spread a uniform light distribution on whatever is below.

The cubes form an abstract silhouette in angles seemingly floating in the air. Blockchain system comes in various of length, starting from 1200mm up to 3000mm continues line, or your own creative way of angles. Engineered and handcrafted in Sweden, locally in Greater Gothenburg Metropolitan, Swedish west coast.







**Markus Johansson (Sweden)** graduated in 2011 from HDK (School of Design and Crafts) in Gothenburg, Sweden. Markus work with both Swedish and international brands and has won numerous awards and is represented at The Museum of Art and Design, New York.

## LIGHTBONE

The Lightbone design by FÄRG & BLANCHE was first shown as part of the Armour Mon Amour exhibition during Milan Design Week 2017. At that time the lamps were in textile and up to 3 meter high and were inspired by a trip to Japan and their bamboo forest.

”We are really happy that we were able to develop the version of the LightBone together with Oblure, this time in solid Oak WOOD and all made in Sweden.”

The name Bone refers to the specific connection made by the spherical glass itself, connecting the wood parts together. The lamp can be easily used as a single piece aside a sofa for example but also as a group or 2 or 3 creating a small forest or many more to divide space in hospitality projects. LighBone comes in natural Oak and with oil-stained Black Oak, Smoked Oak and Cobalt blue, it is also available in custom color on request.





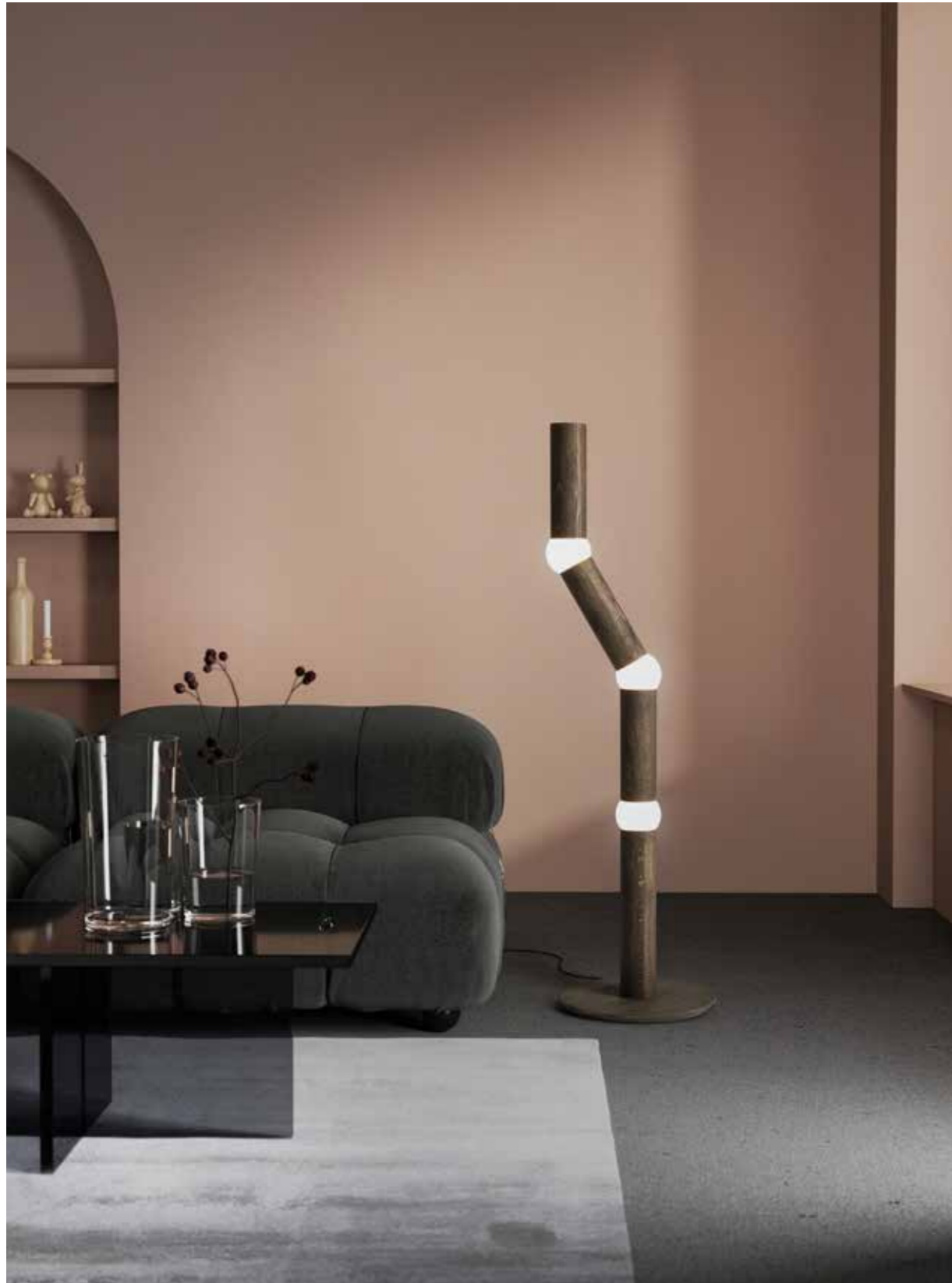



**FÄRG & BLANCHE (Sweden)** was founded in 2010 by the Swedish designer Fredrik Färg and designer Emma Marga Blanche, born in France. As a studio, they work across a wide variety of fields, collaborating with established furniture brands such as BD Barcelona Design, Gärsnäs, Rörstrand, Petite Friture and Design House Stockholm to name a few, as well as producing their own collections and limited art pieces for galleries.



## STAIR LAMP

STAIR draws inspiration from the basic geometry of a solid stair block. The sphere creates curiosity while resting on the edge of time. A ``snapshot`` of movement in a series of events creates a strong symbolic look. When the globe is lit, it results in a beautiful shadow play.

The distinctive shape hides a set of functions as STAIR is equipped with a hidden electrical outlet underneath and two USB -C ports on the side. In a digital world where people see technology as a matter of course, this provides many user possibilities.











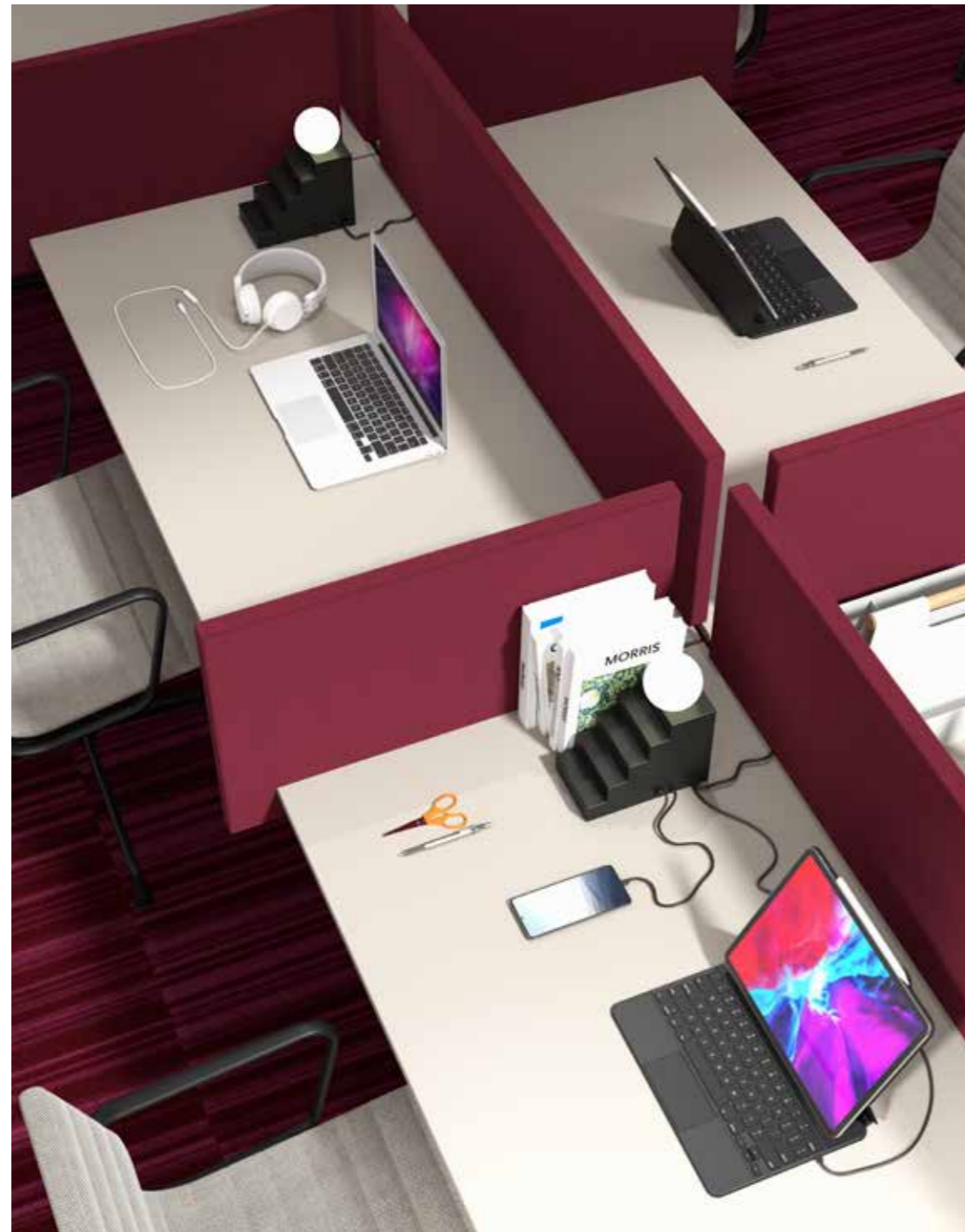

**Notchi Architects (Sweden)** integrates architecture and visual arts. Working with products, installations and architecture the understanding of the relation between space and object is strong and the quest to find the right objects for a specific space sometimes results in new products.

## BALANCE

All entities move and nothing remains still. Balance plays with the concept of time - everything is in motion. The impossible position of the orbs is an expression of the fragility of existence. The group of spheres stuck in time is a reminder to the beholder that life always moves, no matter what.

The construction is made from of a pair of glowing orbs poised between two slanted steel boards. The metal spheres seen on both sides have just the right density to counterweight the opposite part of the lamps' weight. the overall structure is grounded by a black marble base.





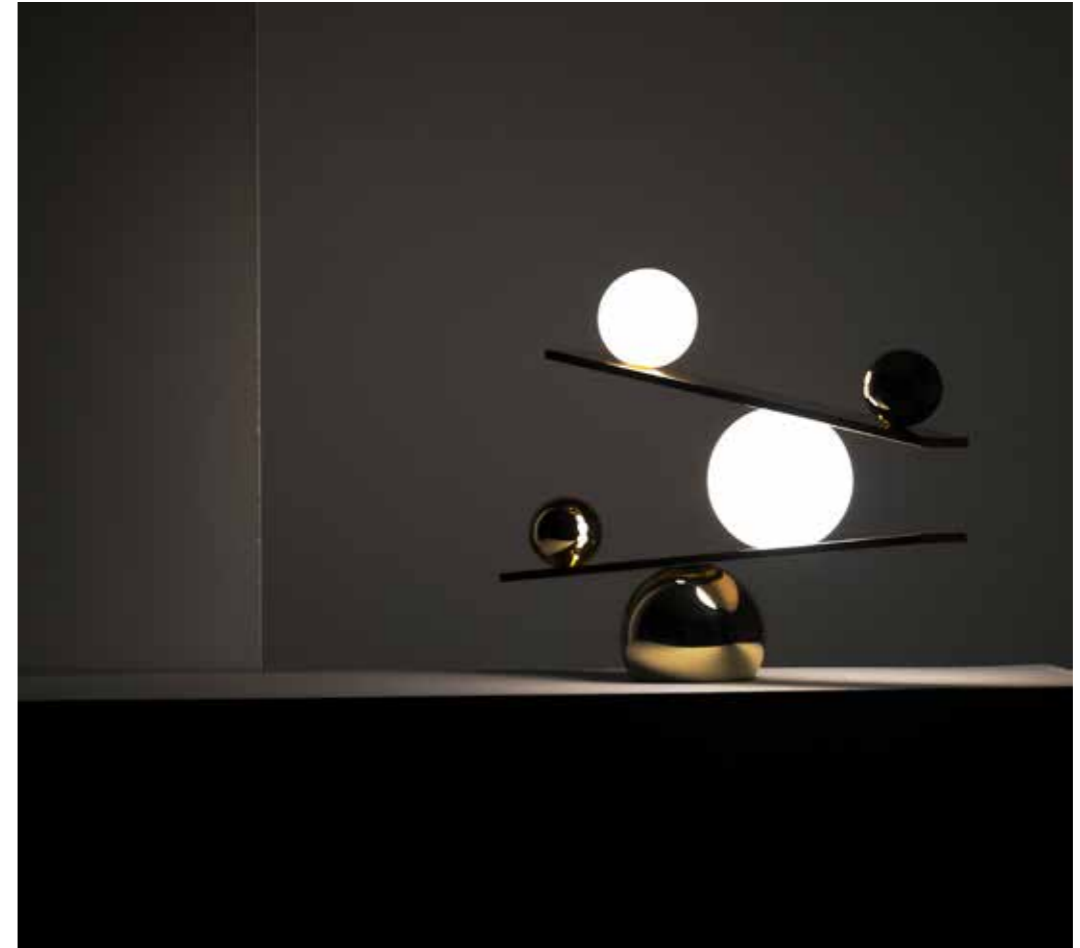





**Victor Castanera (Spain)** loves to experiment and the search for the different and emotional often result in the use of new techniques and materials. Living and working in Barcelona the Mediterranean culture is a big inspiration as well as his passion for the nature and the sea. The result is a collection of objects and products that speak for themselves in the simplest possible way.



## ARCH

An arch shape travels from light to light and in its entirety a pendant that resemble and shows appreciation to the architectural arches/vaults that has been built for centuries. The seven pillars equipped with a light source each will provide downlight on our various spaces at home as well as public spaces. Perfect for kitchen tables, -islands, conference rooms and offices. The fixture has an alluring and eye-catching design that consists of a metal exterior in multiple colors.

The newly launched Arch quickly became a favorite and it wasn't long before several constellations were in demand. The architectural arches are still the foundation in construction and design but now in a new dress and aesthetic. "We see this member as an extension and with this contribution the Arch's has now become a family.

With "The Arch Circle" the circle closes in its proper sense.













**Johan Lindsten (Sweden)** was born in 1981 in the heart of, 'Möbelriket', the furniture kingdom of Sweden. Profiting from a vast knowledge about the industry at an early age he successfully graduated in the program of furniture design in Stockholm in 2008, leading to the establishment of the independent Design Studio Johan Lindstén Form.

**Markus Johansson (Sweden)** graduated in 2011 from HDK (School of Design and Crafts) in Gothenburg, Sweden. Markus work with both Swedish and international brands and has won numerous awards and is represented at The Museum of Art and Design, New York.

## MONDO

Mondo pendant has a classic soul but contemporary ambitions. It combines a planetary physical image with an abstract concept of originality programmed by the beholder. The possibility of interacting with the lamp offers the user an infinite dialogue.

The overlapping patterns control the luminous effect through the movement of the metallic shades. Antonio Facco has created a sophisticated lamp that invites the user to become a co-designer.





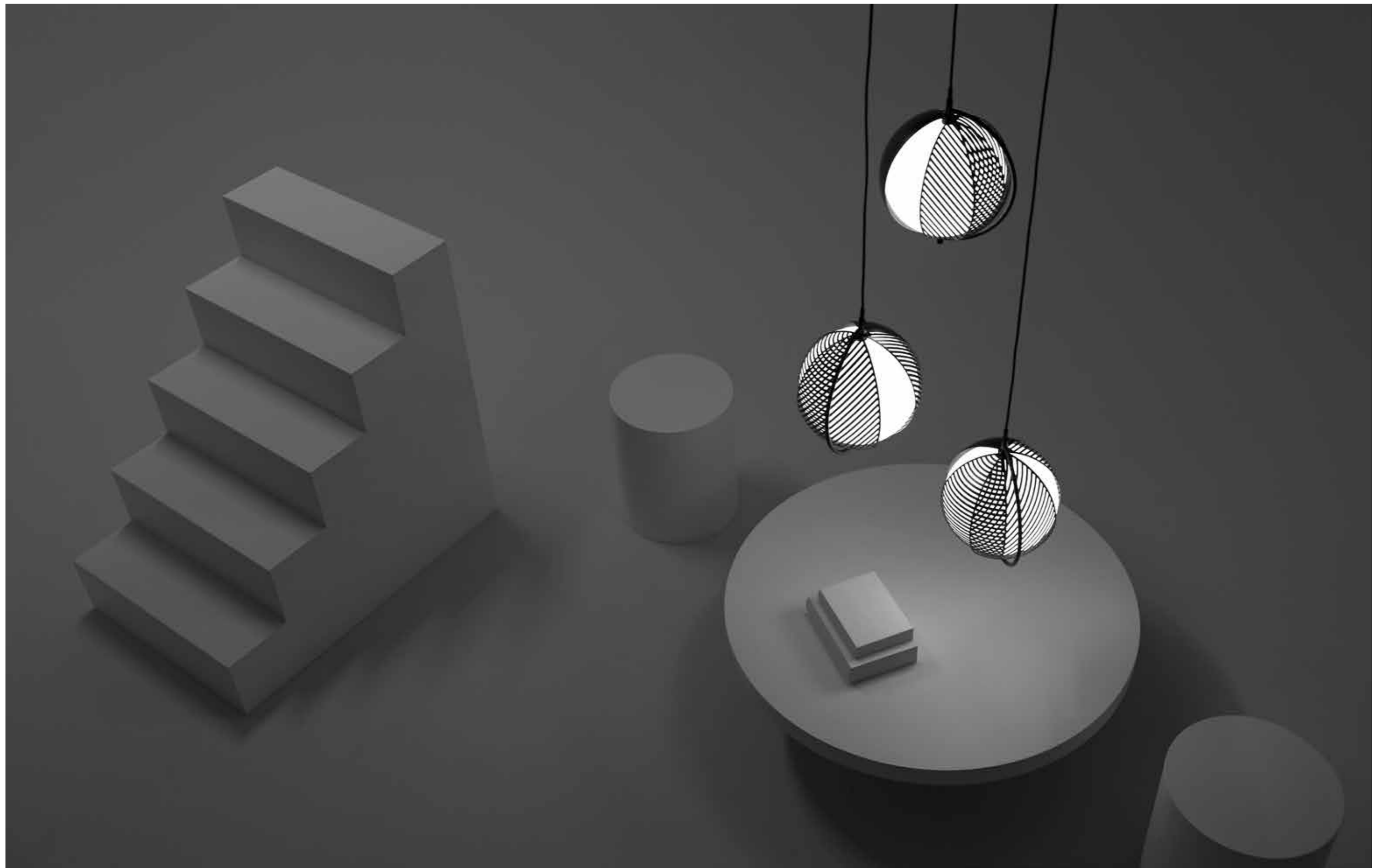

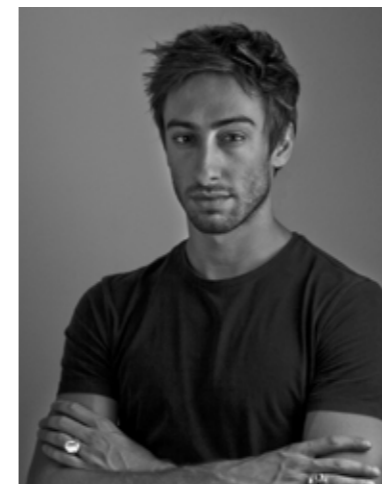

**Antonio Facco (Italy)** always paid great attention to the evolution of contemporary design and communication. Through the analysis of new generations' behavior and habits he draws hints and inspiration for his own research and projects.



## TRAPEZE

Trapeze is a true artist, an aerialist combining grace and style. Fixed in a single pose with endless possibilities. Each shade can be directed 360 degrees which allows the user to combine uplight and downlight at the same time. A playful and bold feature that also is pragmatic and practical in use.

Trapeze is available in three versions. The single pendant with two shades, the 'triple' with six shades or the 'quartette' with eight shades. All these fixtures makes it possible to adjust and direct the light where it is needed.





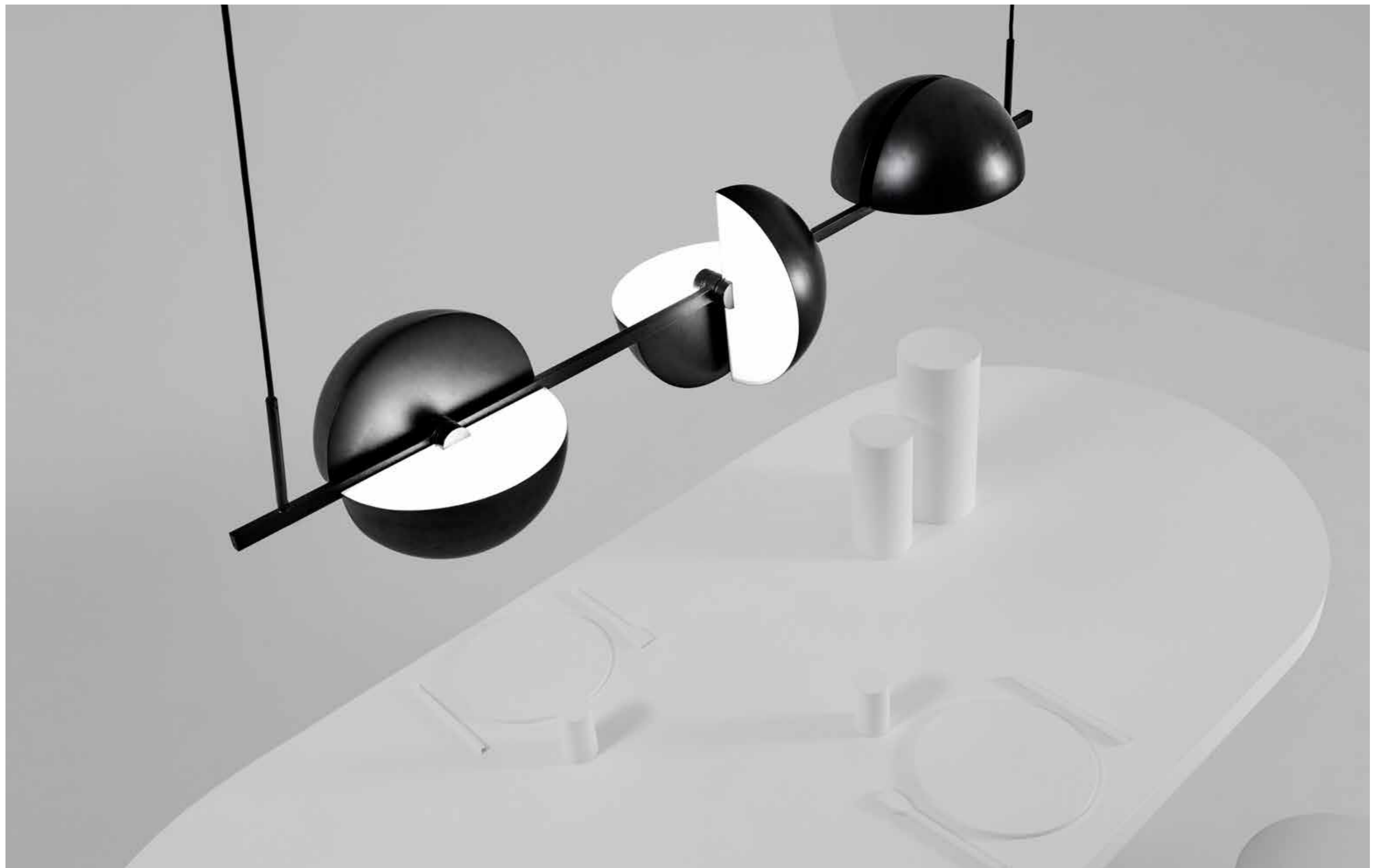









**Jette Scheib (Germany)** studied Industrial Design at the University of the Arts in Berlin. "I am inspired by nature and organic shapes, but also by people and everyday life. I am observing my surroundings, I study objects, people, people interacting with objects and each other."

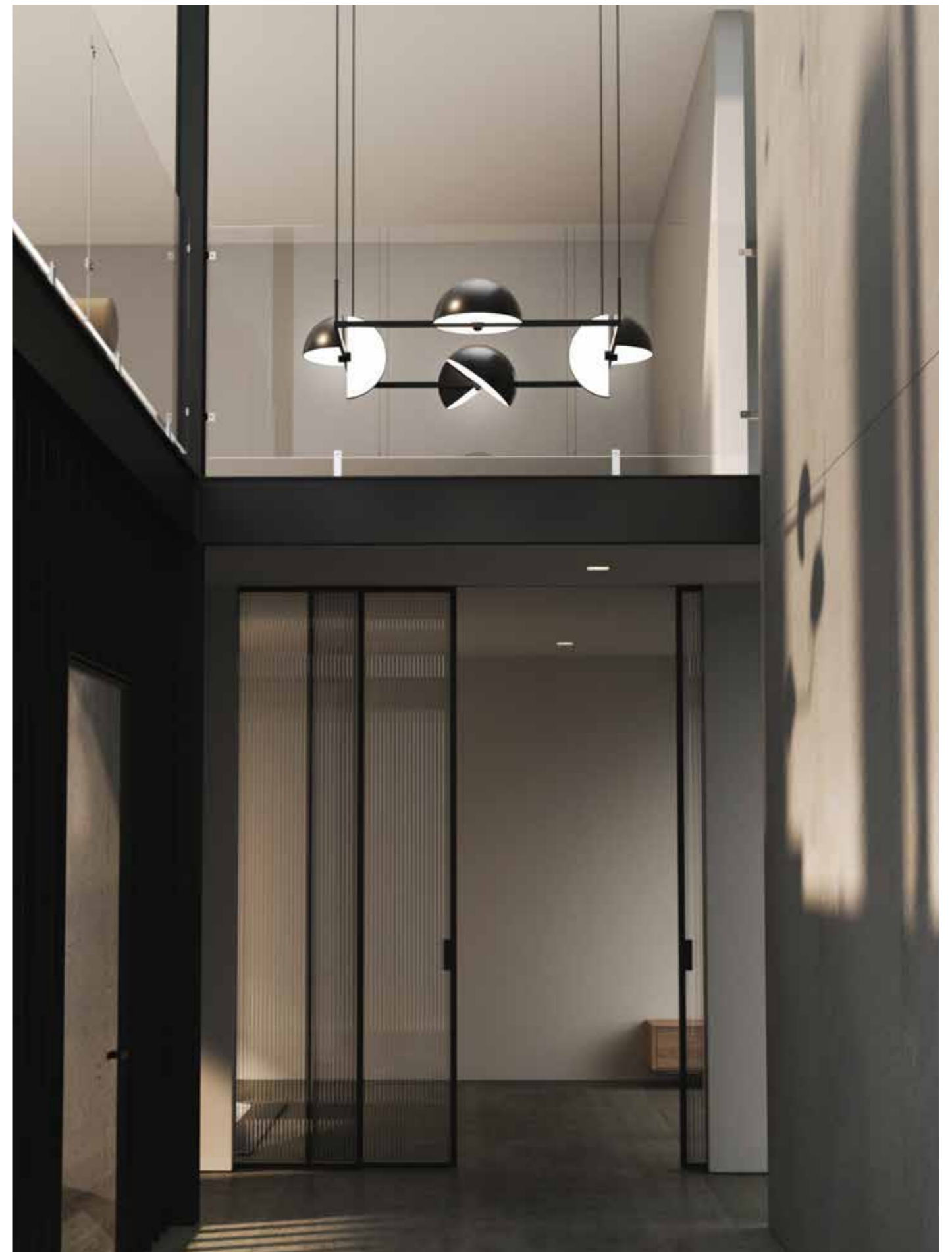

## HELIOS

Helios is an aspiration to reinvent the classical chandelier – but instead of reflecting and diffusing, the rods project and enhance the light. Each of the 240 acrylic rods are lit by an individual LED, hidden in the center of the lamp. The pendant is two faced – when turned off Helios has a cold and crisp appearance. Turned on, the lamp comes alive, and the intensity of the many acrylic rods portray a glowing sphere resembling the sun. An almost transcendental appearance.

The majestic crystal chandelier has now become a glowing half sphere. With its 120 Japanese acrylic rods, mirroring chrome details give the fixture a elegant but yet bold appearance. Each acrylic rod is lit by an individual LED and there is also a slightly backlight to eliminate dark shadows on the ceiling, instead it creates a magical halo - effect.







**Joakim Thedin (Sweden)** has been working as a product designer since 1997, both with objects for public and home environment. The last years he has been focusing on light design and has mainly worked with Swedish brands. Helios is his first product for Oblure.





## CIRRATA

Unexpected experiences and surprises wait deep down on the ocean floor: a body with many arms lights up the depth. Arrogant and presumptuous, there is no doubt about who is the ruler down here. A lonely but nevertheless unafraid character with forms born out of the

resemblance to other inhabitants of the unknown. The character is *Cirrata*, a glowing lamp in the darkness of the ocean. Markus Johansson has created a lamp that challenges all ideas about what is possible to make out of aluminium. The symmetrical arms equally carry the weight of the lamp.









**Markus Johansson (Sweden)** graduated in 2011 from HDK (School of Design and Crafts) in Gothenburg, Sweden. Markus work with both Swedish and international brands and has won numerous awards and is represented at The Museum of Art and Design, New York.



## NOTIC

Notic is an homage to classical architectural elements. The graphical metal shade embraces the complex geometry of the glass and spreads the light in a hypnotic way. The lamp has a focused down light combined with a gentle illumination through the shade. With the resemblance of a hypnotic pendulum the beholder might even find something within themselves.

The idea behind the lamp was to design a focus point in a three-dimensional space. A room needs virtual lines and directions to guide the visitor but also to create defined spatiality. The pattern does not only work as a design element and a way to spread the light, the sharp contrast also draws immediate attention.









**Notchi Architects (Sweden)** integrates architecture and visual arts. Working with products, installations and architecture the understanding of the relation between space and object is strong and the quest to find the right objects for a specific space sometimes results in new products.



# TECHNICAL SPECIFICATIONS

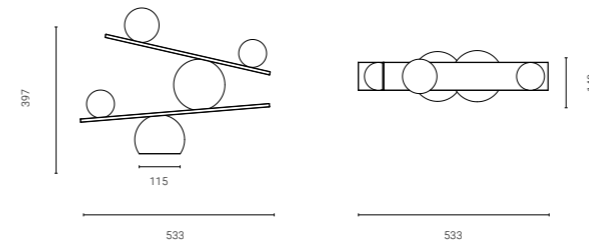

## Balance Table P. 26

Victor Castanera, Spain

**Description:** Table lamp with two lights. Cable with rotary dimmer switch. Handblown opal glass. Glossy paint with marble base (Black), plated brass with steel base (Brass).

Environment: Indoor  
 Watt: 5,5 w (3,5w + 2w) (2700 Kelvin)  
 Measurements: 397 mm (H), 533 mm (L), 140 mm (W)  
 Cord: 180 cm  
 Fitting: LED tube , G4 LED (replaceable)

- Colors: Black **VCBA1003** ●  
 Brass **VCBA1010** ●

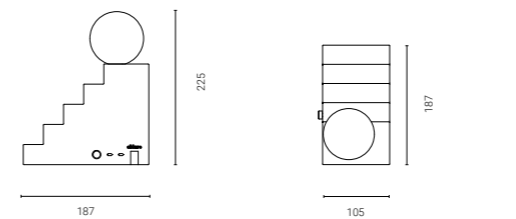

## Stair Table P. 16

Notchi Architects, Sweden

**Description:** Table lamp in steel and opal glass sphere equipped with G9 socket and rotary dimmer switch. The lamp also features with 2 x USB C ports for battery charging and an hidden power outlet underneath.

Environment: Indoor  
 Watt: Max 3 W (LED)  
 Measurements: 225 mm (H), 187 mm (L), 105 mm (W)  
 Cord: 300 cm  
 Fitting: G9 (Light source not included)  
 Futures: 2 x USB-C & 1 power outlet

- Colors: Black **NAST1003** ●  
 Beige **NAST1004** ●  
 Yellow **NAST1005** ●  
 Red **NAST1007** ●

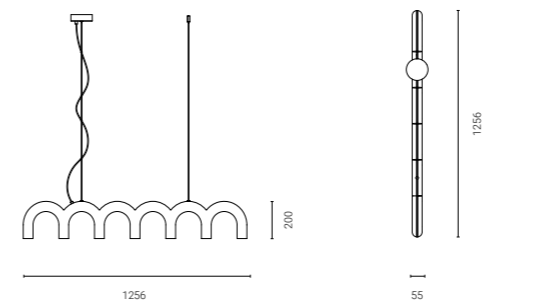

## Arch Pendant P. 32

Johan Lindsten (Sweden) Markus Johansson, Sweden

**Description:** Pendant lamp in steel, bent and welded by hand. Each seven pillars equipped with a light source, GU10 socket. The lamp is suspension details are in chrome finish, as well as the ceiling canopy. Suspension wires are adjustable with a gridlock and power cable in transparent cover.

Environment: Indoor  
 Watt: max 7 x 20 W (LED)  
 Measurements: 200 mm (H), 1256 mm (L), 55mm (W)  
 Cord: 300 cm  
 Fitting: GU10 (Light source not included)

- Colors: Black **MJAR2003** ●  
 White **MJAR2001** ●  
 Blue **MJAR2006** ●  
 Nude **MJAR2008** ●  
 Custom **MJAR20XX** ●

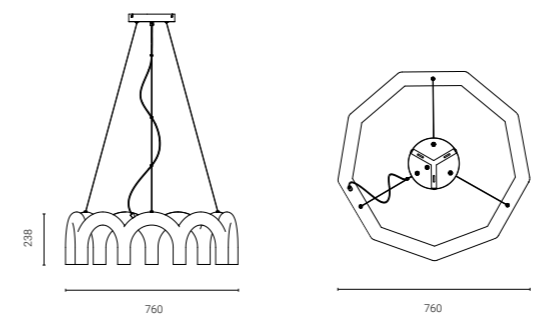

## Arch Circle P. 38

Johan Lindsten (Sweden) Markus Johansson, Sweden

**Description:** Pendant lamp in steel, bent and welded by hand. Each seven pillars equipped with a light source, GU10 socket. The lamp is suspension details are in chrome finish, as well as the ceiling canopy. Suspension wires are adjustable with a gridlock and power cable in transparent cover.

Environment: Indoor  
 Watt: max 7 x 20 W (LED)  
 Measurements: 200 mm (H), 1256 mm (L), 55mm (W)  
 Cord: 300 cm  
 Fitting: GU10 (Light source not included)

- Colors: Black **MJAR2003** ●  
 White **MJAR2001** ●  
 Blue **MJAR2006** ●  
 Nude **MJAR2008** ●  
 Custom **MJAR20XX** ●



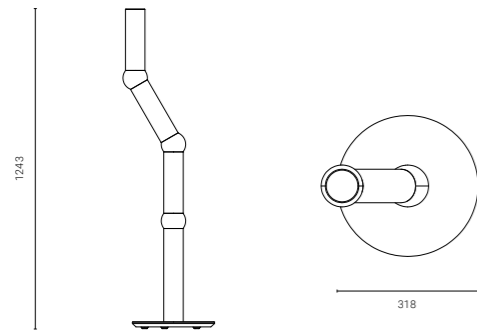

### Lightbone Floor lamp P. 10

Färg & Blanche, Sweden

**Description:** Steel with acrylic diffuser. Pendant lamp providing light in six directions at the same time. Painted black with textile cable and two ceiling cups.

Environment: Indoor  
 Watt: Max 6 x 20 w  
 Measurements: 1400 mm (L) x 281 mm (W) x 147 mm (H)  
 Cord: 120cm  
 Fitting: 6 x E14 (not included)

- Colors: Blue oak JSTR2003-X3 ●  
 Black oak JSTR2003-X3 ●  
 Smoaked oak JSTR2003-X3 ●  
 oljed oak JSTR2003-X3 ●

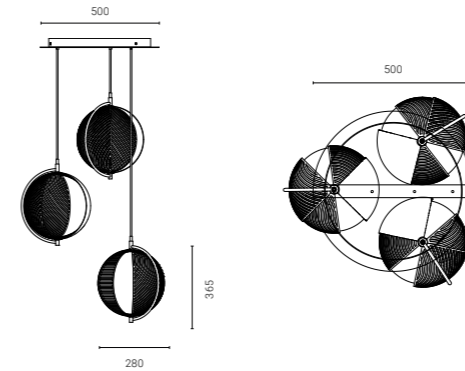

### Mondo Triplette P. 44

Antonio Facco, Italy

**Description:** Configuration of three Mondo pendants. The movable shades allow the beholder to interact with the lamp. Finished with matt Black paint.

Environment: Indoor  
 Watt: Max 3x40w  
 Measurements: Each lamp: 365 mm (H), 280 mm (Ø),  
 Canopy: 500 mm (Ø), 38 mm (H)  
 Cord: 300cm  
 Fitting: E27 (not included)

- Colors: Black AFMO2003-X3 ●

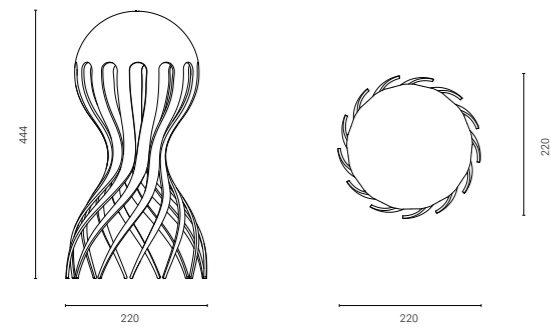

### Cirrata Table P. 68

Markus Johansson, Sweden

**Description:** Table lamp in casted aluminium with a decorative light effect. Textile cable with dimmer switch.

Environment: Indoor  
 Watt: 3.2 W  
 Measurements: 444 mm (H), 220 mm (Ø)  
 Cord: 180cm  
 Fitting: LED (replaceable)

- Colors: White MJCI1001 ○  
 Grey MJCI1002 ●

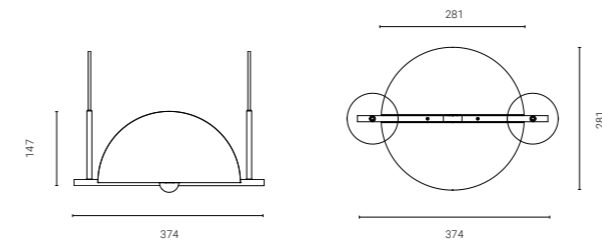

### Trapeze Pendant P. 50

Jette Scheib, Germany

**Description:** Steel and brass with acrylic diffuser. Pendant lamp providing light in two directions at the same time. Painted black with textile cable and two ceiling cups.

Environment: Indoor  
 Watt: Max 2 x 20 w  
 Measurements: 281 (H), 374 mm (Ø)  
 Cord: 300cm  
 Fitting: 2 x E14 (not included)

- Colors: Black JSTR2003 ●

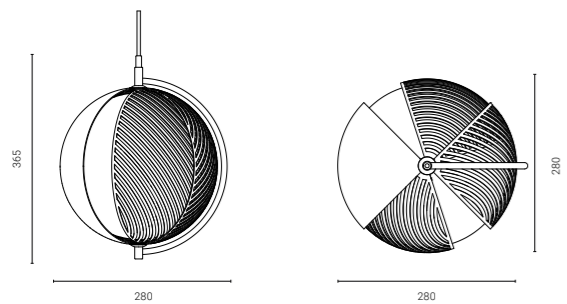

### Mondo Pendant P. 42

Antonio Facco, Italy

**Description:** Steel and opal glass. Pendant lamp with four metal shades, mounted in pairs. Allows the beholder to interact with the lamp.

Environment: Indoor  
 Watt: Max 40w  
 Measurements: 365 mm (H), 280 mm (Ø)  
 Cord: 300cm  
 Fitting: E27 (not included)

- Colors: Black AFMO2003 ●

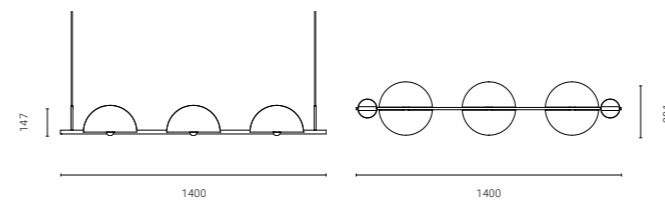

### Trapeze Triplette P. 54

Jette Scheib, Germany

**Description:** Steel with acrylic diffuser. Pendant lamp providing light in six directions at the same time. Painted black with textile cable and two ceiling cups.

Environment: Indoor  
 Watt: Max 6 x 20 w  
 Measurements: 1400 mm (L) x 281 mm (W) x 147 mm (H)  
 Cord: 300cm  
 Fitting: 6 x E14 (not included)

- Colors: Black JSTR2003-X3 ●

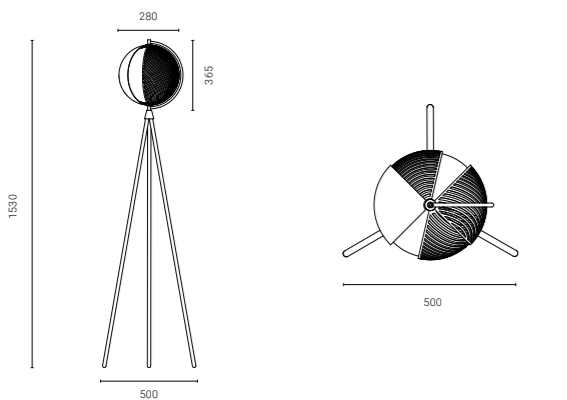

### Mondo Floor P. 48

Antonio Facco, Italy

**Description:** Floor lamp with four metal shades, mounted in pairs. Allows the beholder to interact with the lamp. Cable with on-off switch.

Environment: Indoor  
 Watt: Max 40w  
 Measurements: 365 mm (H), 280 mm (Ø) (Shade/glass) 1530 mm (H), 500 mm (Ø) (Height/base)  
 Cord: 180cm  
 Fitting: E27 (not included)

- Colors: Black AFMO3003 ●

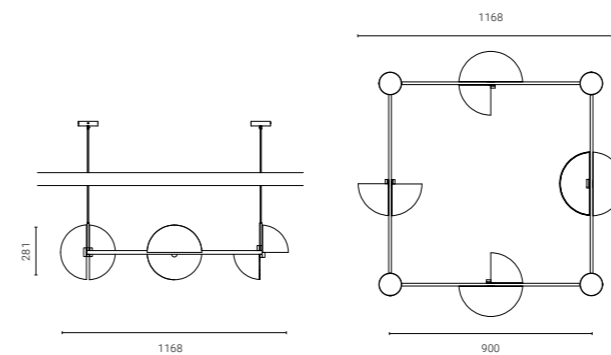

### Trapeze Quartette P. 59

Jette Scheib, Germany

**Description:** Steel and brass with acrylic diffuser. Configuration of four pendant lamps providing light in eight directions at the same time. Painted black with textile cable and 8 ceiling cups (4 electric points).

Environment: Indoor  
 Watt: Max 8 x 20 w  
 Measurements: 854 mm (L) x 854mm (W) x 147 mm (H)  
 Cord: 300cm  
 Fitting: 8 x E14 (not included)

- Colors: Black JSTR2003-X4 ●



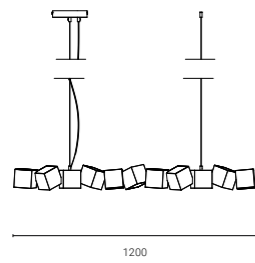

1200



100

### Blockchain 11 P. 4

Markus Johansson, Sweden

**Description:** Table lamp in patterned steel and casted opal glass. Complex geometry, textile cord.

Environment: Indoor  
Watt: Max 25 w  
Measurements: 475 mm (H), 153 mm (W), 153 mm (D)  
Cord: 2100 mm  
Fitting: G9 (not included)

Colors: Black BSNO1002

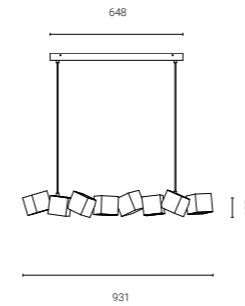

648

931

128

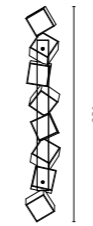

931

128

### Blockchain 8 P. 4

Markus Johansson, Sweden

**Description:** Pendant lamp providing down-light from 4 cubes. Dimmable LED driver is provided and fitted in the canopy.

Environment: Indoor  
Watt: 4x3 w (3000 Kelvin)  
Measurements: 134 mm (H), 931 mm (L), 134 mm (W)  
Cord: 300 cm  
Fitting: LED (replaceable)

Colors: Black BSNO1002

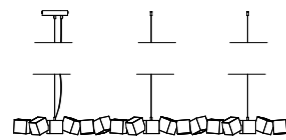

1863



100

### Blockchain 17 P.4

Markus Johansson, Sweden

**Description:** Configuration of three Notic pendant lamps. Made in patterned steel and casted opal glass. Complex geometry, textile cord.

Environment: Indoor  
Watt: Max 3 x 25 w  
Measurements: 475 mm (H), 153 mm (W), 153 mm (D),  
Canopy: 500 mm (Ø), 38 mm (H)  
Cord: 300 cm  
Fitting: 3 x G9 (not included)

Colors: Black BSNO2003-X3

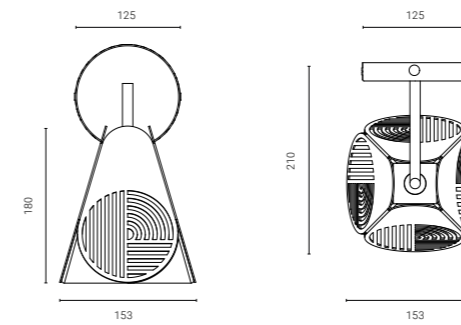

125

180

153

125

210

153

### Notic Wall P. 74

Notchi, Sweden

**Description:** Wall lamp in patterned steel and casted opal glass. Complex geometry, textile cord.

Environment: Indoor  
Watt: Max 25w  
Measurements: 180 mm (H), 153 mm (W), 153 mm (D),  
210 mm (From wall to edge of the shade)  
Cord: 180 cm  
Fitting: G9 (not included)

Colors: Black BSNO4002

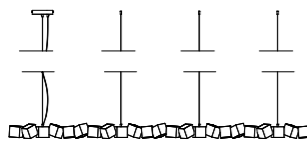

2520



100

### Blockchain 23 P. 4

Markus Johansson, Sweden

**Description:** Modern chandelier made from acrylic glass and plated steel. 240 transparent rods, each lit with a LED.

Environment: Indoor  
Watt: Max 2 x 20 w  
Measurements: 534 mm (H), 600 mm (Ø)  
Cord: 300 cm  
Fitting: Custum LED

Colors: Black JTJE2011

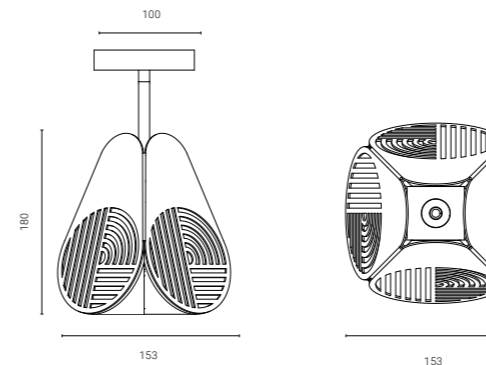

100

180

153

125

210

153

### Notic Ceiling P. 76

Notchi, Sweden

**Description:** Wall lamp in patterned steel and casted opal glass. Complex geometry, textile cord.

Environment: Indoor  
Watt: Max 25w  
Measurements: 180 mm (H), 153 mm (W), 153 mm (D)  
Cord: 300 cm  
Fitting: G9 (not included)

Colors: Black BSNO2002

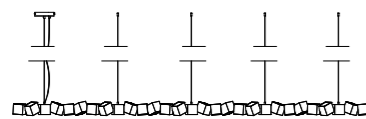

3175

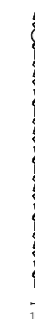

100

### Blockchain 29 P. 4

Markus Johansson, Sweden

**Description:** Steel and brass with acrylic diffuser. Pendant lamp providing light in two directions at the same time. Painted black with textile cable and two ceiling cups.

Environment: Indoor  
Watt: Max 2 x 20 w  
Measurements: 281 (H), 374 mm (Ø)  
Cord: 300cm  
Fitting: 2 x E14 (not included)

Colors: Black JSTR2003

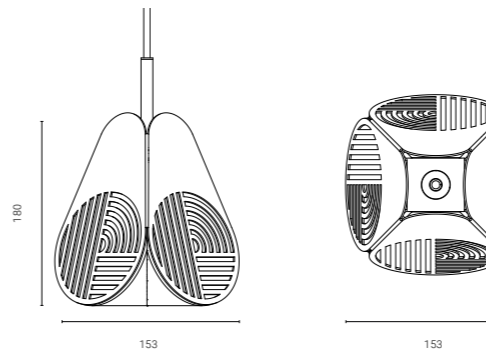

180

153

125

210

153

### Notic Pendant P. 76

Notchi, Sweden

**Description:** Pendant lamp in patterned steel and casted opal glass. Complex geometry of the glass, textile cord.

Environment: Indoor  
Watt: Max 25w/ 220-240v  
Measurements: 180 mm (H), 153 mm (W), 153 mm (D)  
Cord: 300 cm  
Fitting: G9 (not included)

Colors: Black BSNO2002



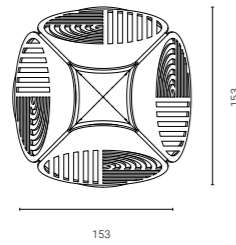
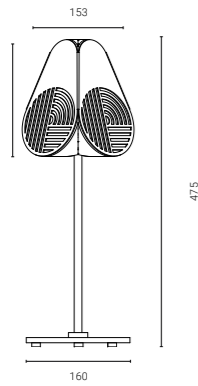

### Notic Table Lamp P. 77

Notchi, Sweden

**Description:** Table lamp in patterned steel and casted opal glass. Complex geometry, textile cord.

Environment: Indoor  
 Watt: Max 25 w  
 Measurements: 475 mm (H), 153 mm (W), 153 mm (D)  
 Cord: 2100 mm  
 Fitting: G9 (not included)

Colors: Black **BSNO1002**

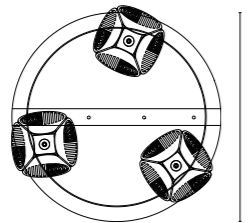
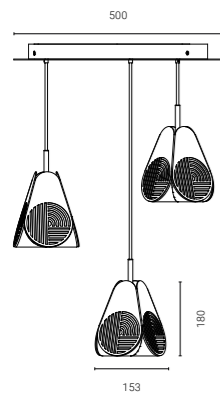

### Notic Triplette P. 76

Notchi, Sweden

**Description:** Configuration of three Notic pendant lamps. Made in patterned steel and casted opal glass. Complex geometry, textile cord.

Environment: Indoor  
 Watt: Max 3 x 25 w  
 Measurements: 475 mm (H), 153 mm (W), 153 mm (D),  
 Canopy: 500 mm (Ø), 38 mm (H)  
 Cord: 300 cm  
 Fitting: 3 x G9 (not included)

Colors: Black **BSNO2003-X3**

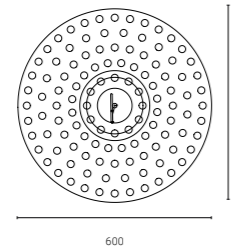
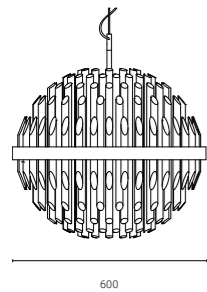

### Helios P. 60

Joakim Thedin, Sweden

**Description:** Modern chandelier made from acrylic glass and plated steel. 240 transparent rods, each lit with a LED.

Environment: Indoor  
 Watt: Max 2 x 20 w  
 Measurements: 534 mm (H), 600 mm (Ø)  
 Cord: 300 cm  
 Fitting: Custom LED

Colors: Chrome **JTHE2011**

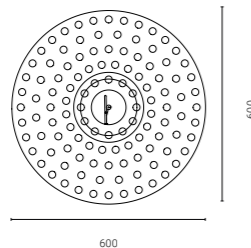
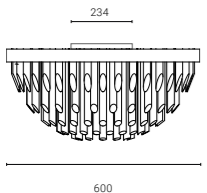

### Helios P. 66

Joakim Thedin, Sweden

**Description:** Modern chandelier made from acrylic glass and plated steel. 240 transparent rods, each lit with a LED.

Environment: Indoor  
 Watt: Max 2 x 20 w  
 Measurements: 534 mm (H), 600 mm (Ø)  
 Cord: 300 cm  
 Fitting: Custom LED

Colors: Chrome **JTHE2011**







OBLURE

FABRIKSGATAN 38

412 51 GOTHENBURG, SWEDEN,

INFO@OBLURE.COM, WWW.OBLURE.COM

0046 31 79 79 896